

DEVELOPMENTS

EXERCISES

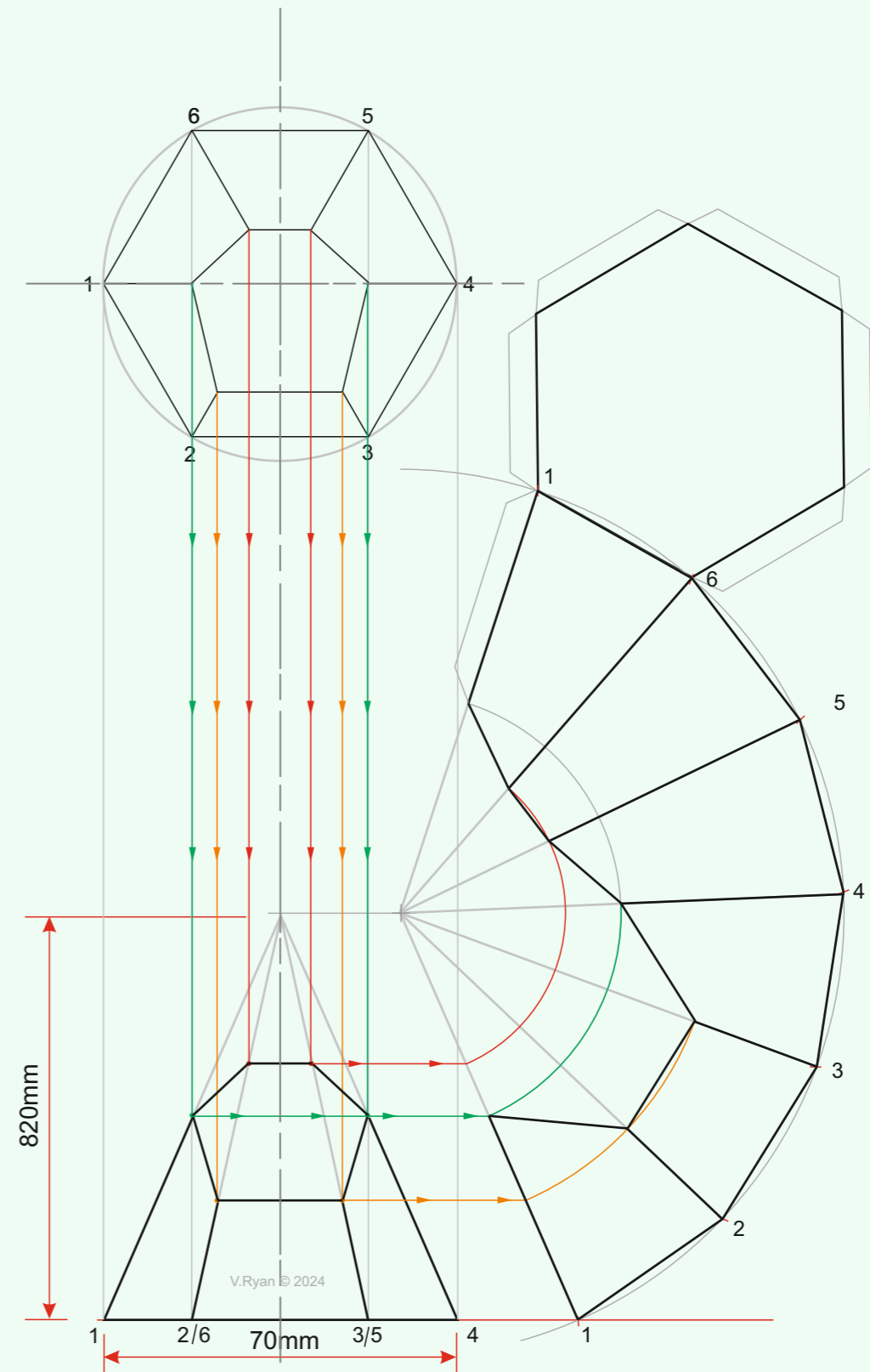
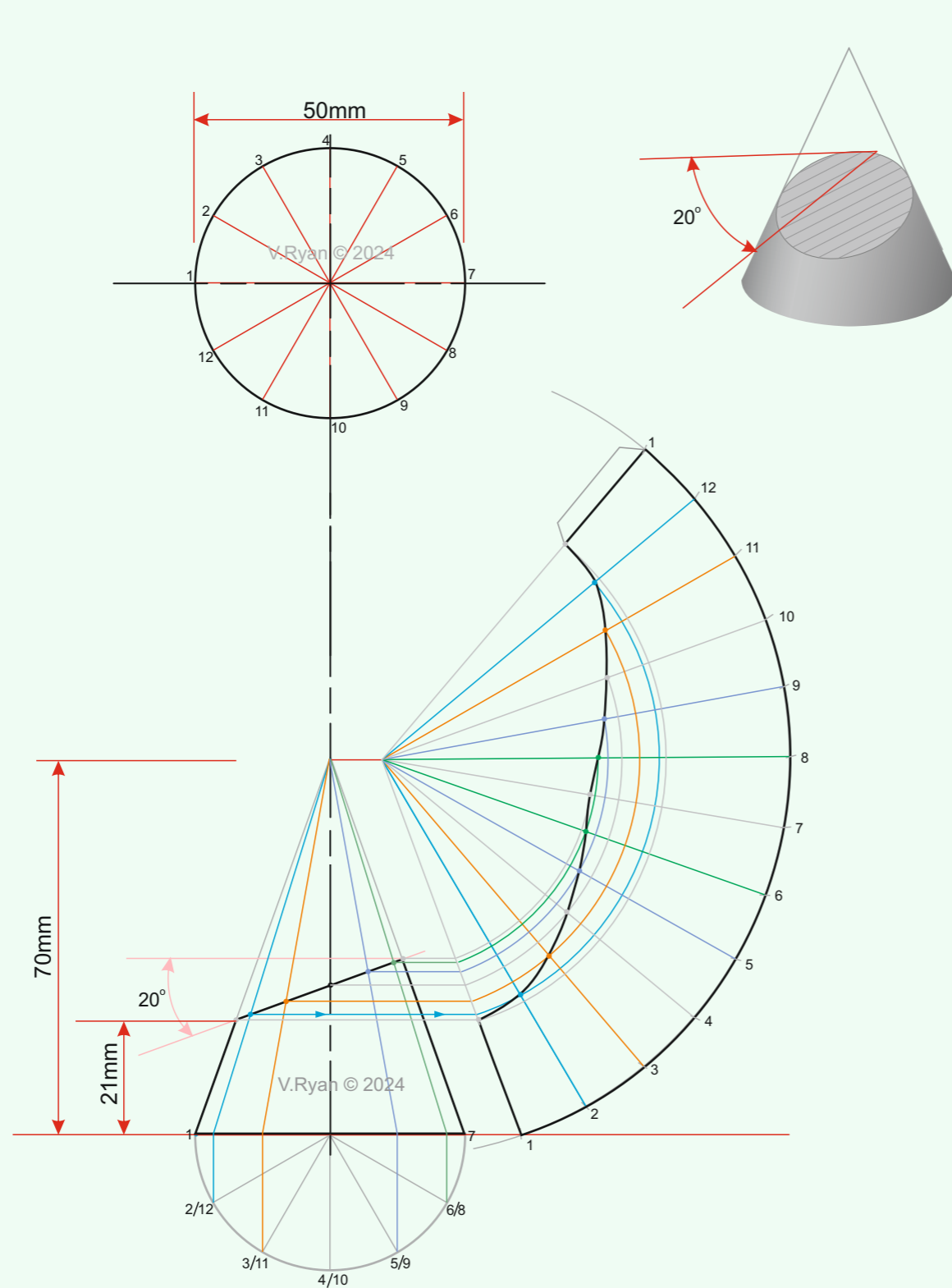

DEVELOPMENTS - SIMPLE CUBOID

HELPFUL LINK: https://technologystudent.com/despro_3/develop1.html

HELPFUL LINK



QUESTION

COMPLETE THE DEVELOPMENT OF THE 'CUBOID PACKAGE' SEEN BELOW. AN ISOMETRIC DRAWING OF THE PACKAGE IS SEEN OPPOSITE.

ISOMETRIC DRAWING

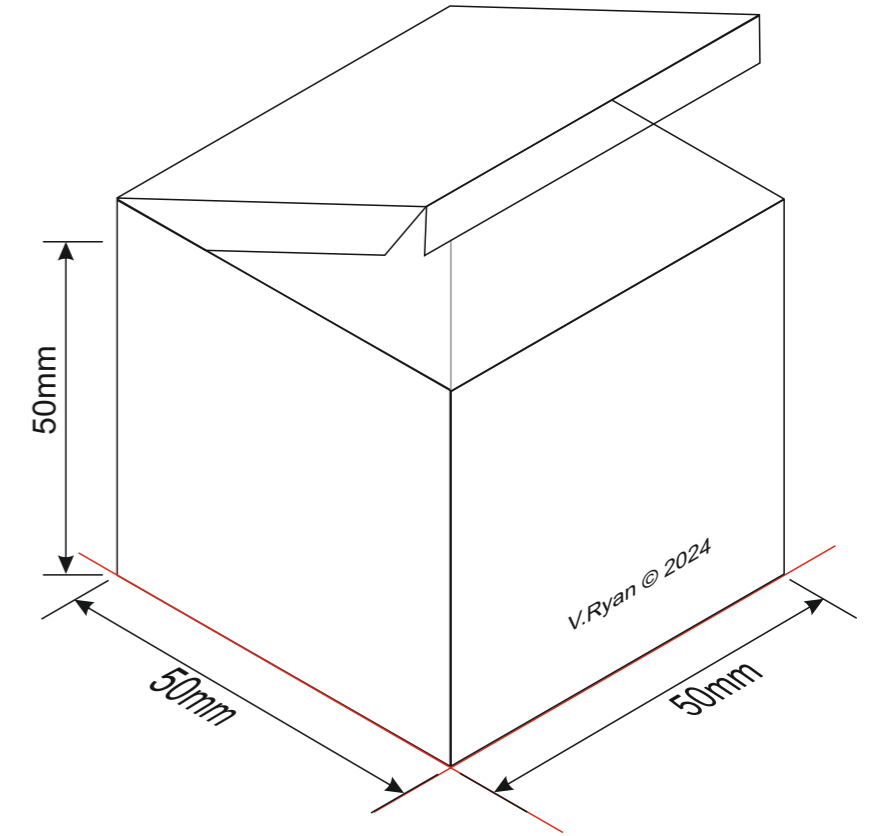

PLAN VIEW

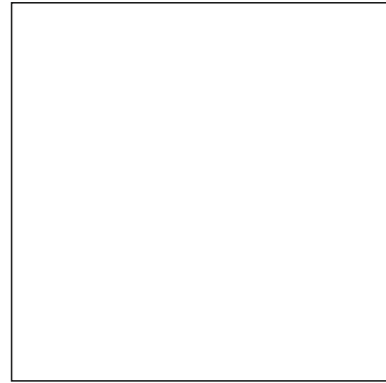

FRONT VIEW

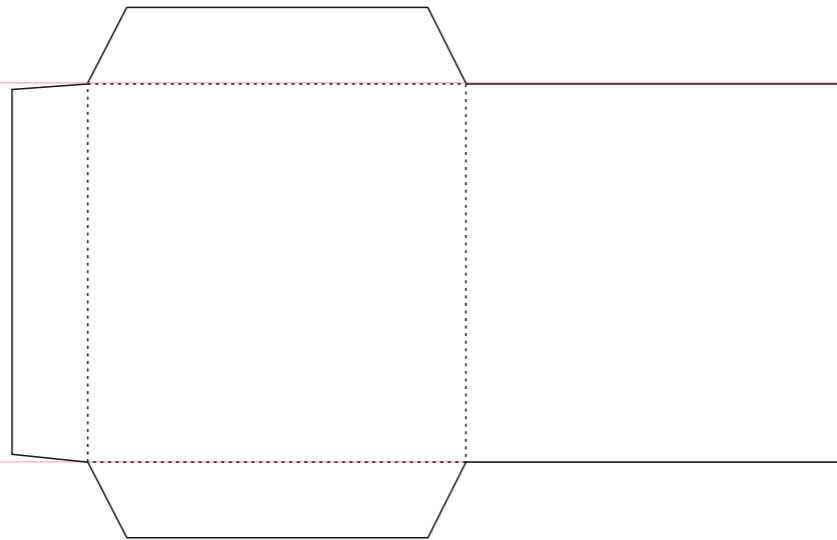
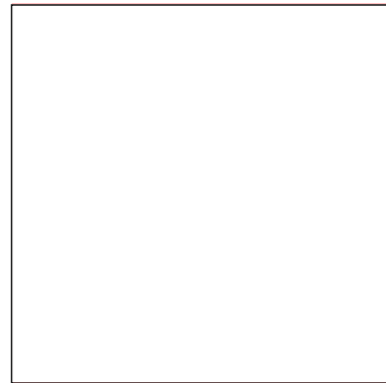

DEVELOPMENTS - SIMPLE CYLINDER

HELPFUL LINK: https://technologystudent.com/despro_3/develp2.html

HELPFUL LINK



QUESTION

COMPLETE THE DEVELOPMENT OF THE 'CYLINDER' SEEN BELOW.
A 3D VERSION OF THE CYLINDRICAL PACKAGE IS SEEN OPPOSITE.

PLAN VIEW

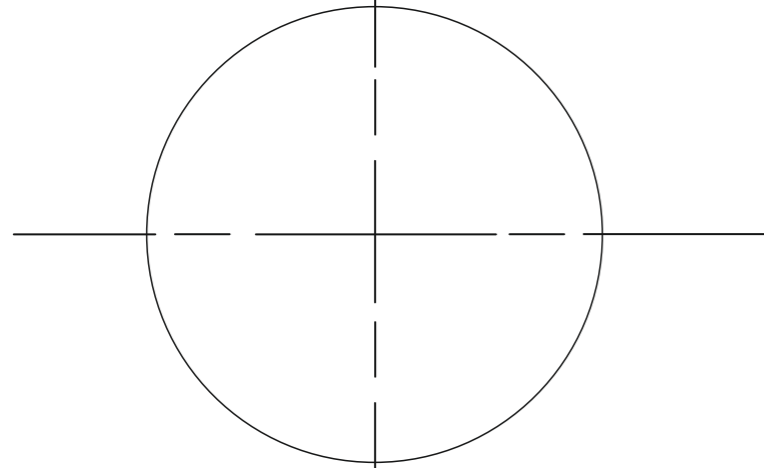

FRONT VIEW

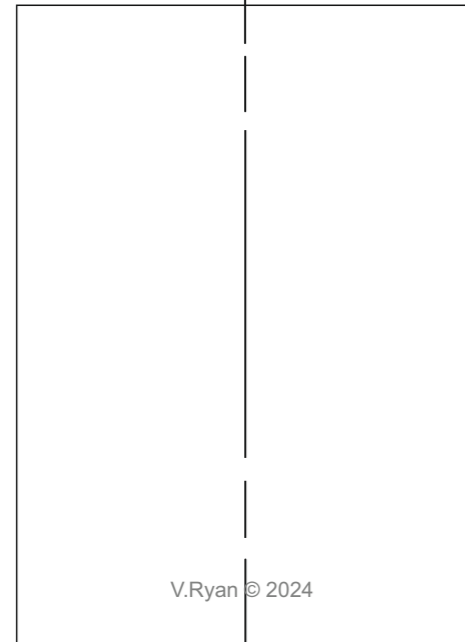

3D VERSION

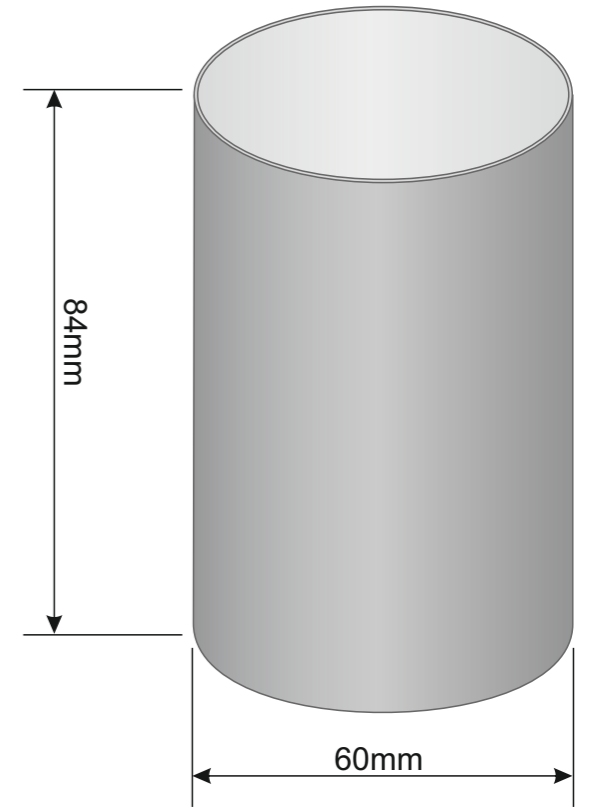

DEVELOPMENTS - SQUARE PRISM

HELPFUL LINK: https://technologystudent.com/despro_3/develp4.html

QUESTION

COMPLETE THE DEVELOPMENT OF THE 'OBJECT' SEEN BELOW. A 3D VERSION OF THE OBJECT IS SEEN OPPOSITE.

HELPFUL LINK

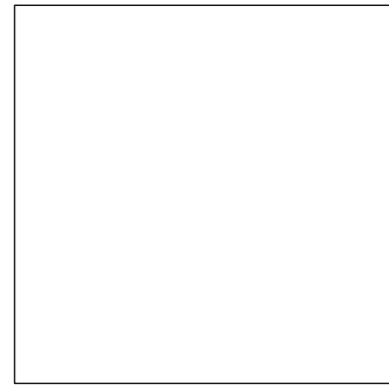

PLAN VIEW

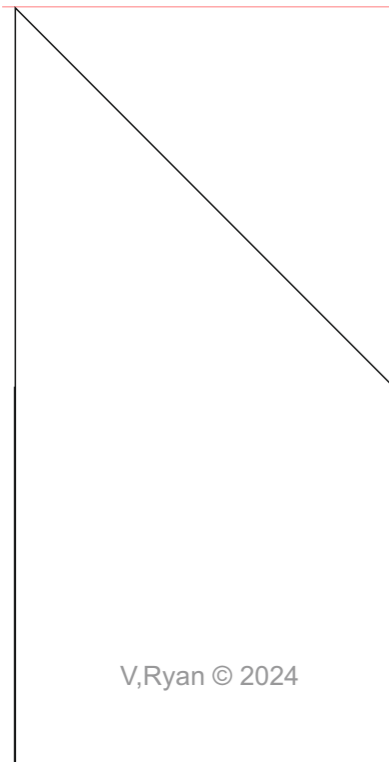
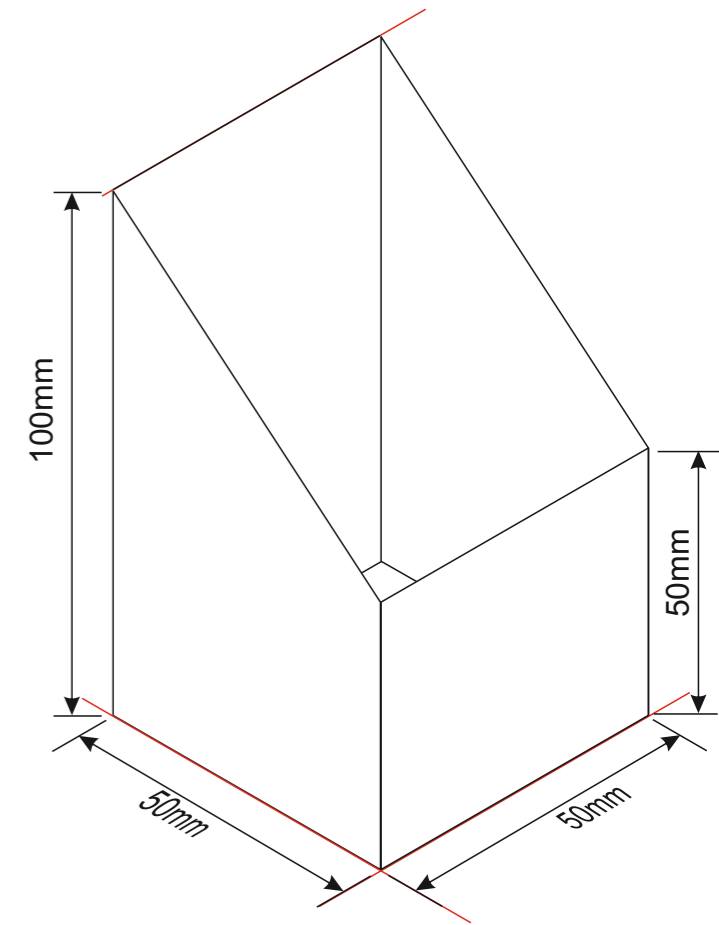

V,Ryan © 2024

SIDE VIEW

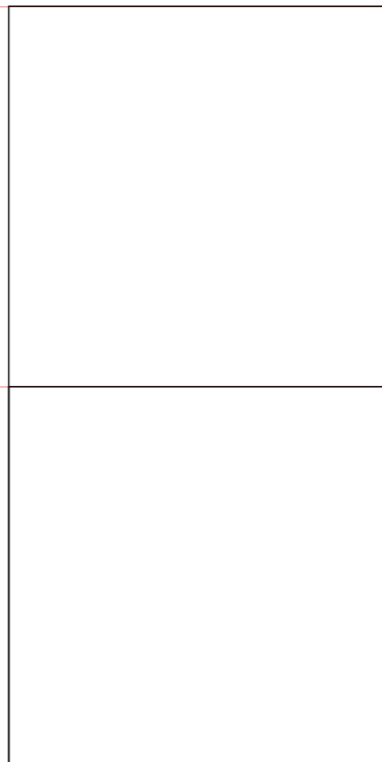

FRONT VIEW

DEVELOPMENTS - TRUNCATED PYRAMID

HELPFUL LINK: https://technologystudent.com/despro_3/develp5.html

QUESTION

COMPLETE THE DEVELOPMENT OF THE TRUNCATED SQUARE PYRAMIDS 1 AND 2.

HELPFUL LINK



1.

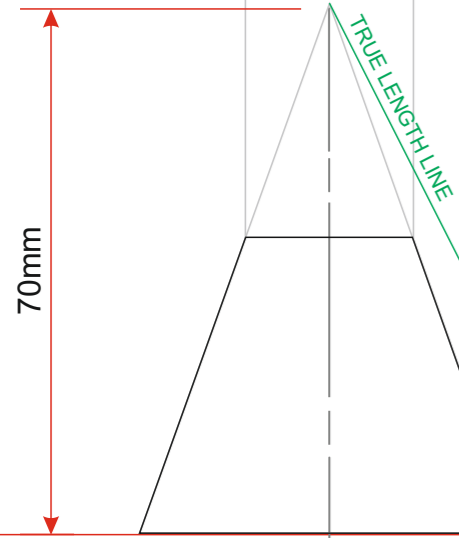
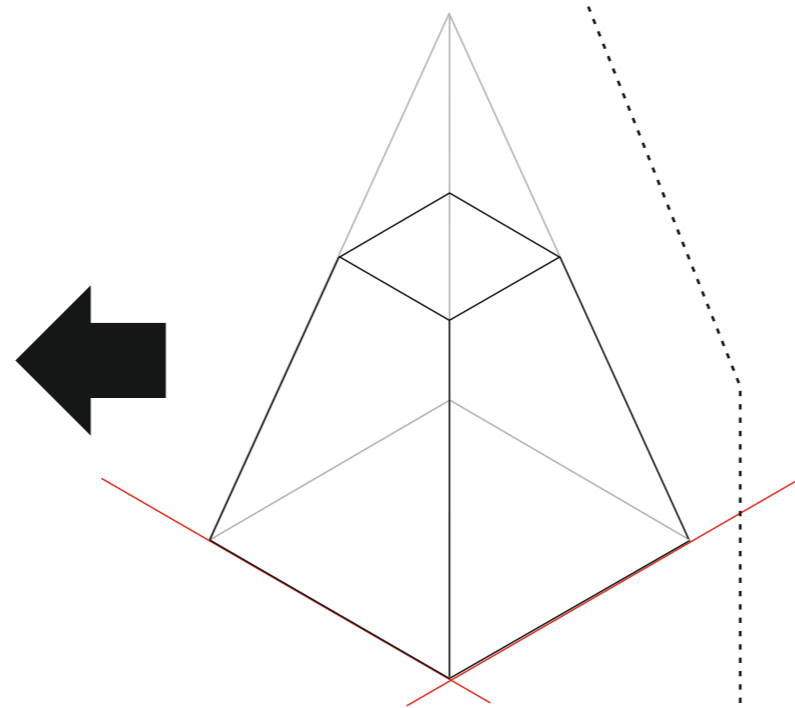
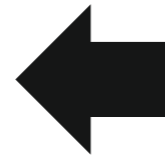
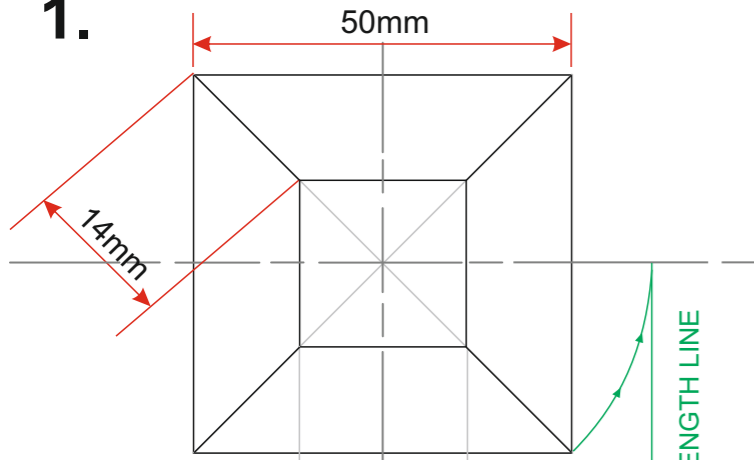

2.

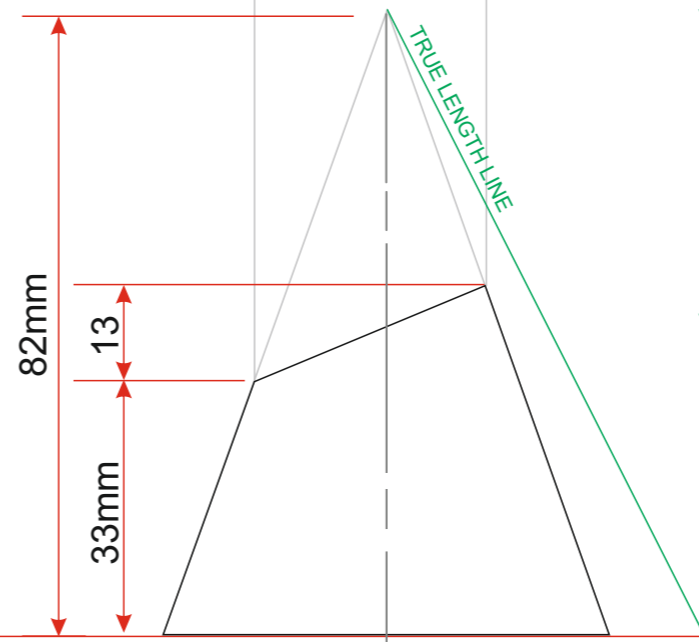
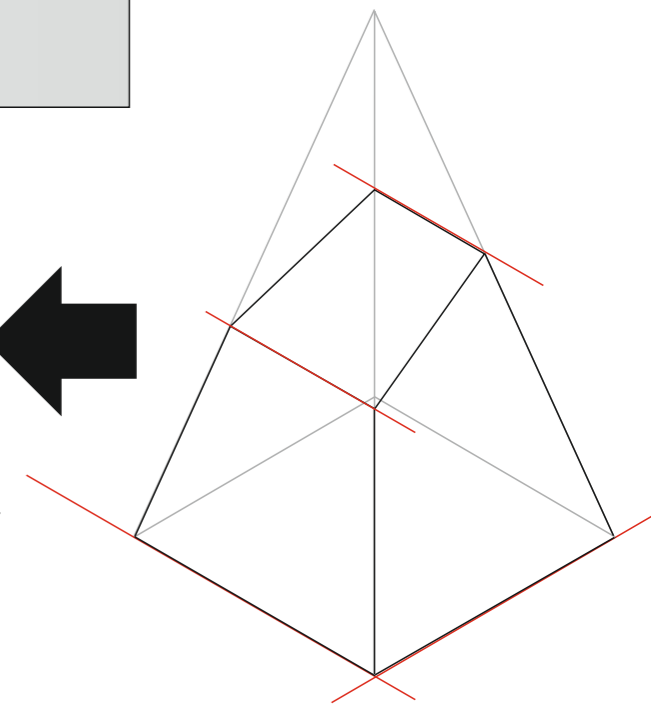
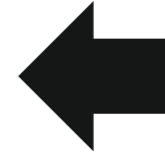
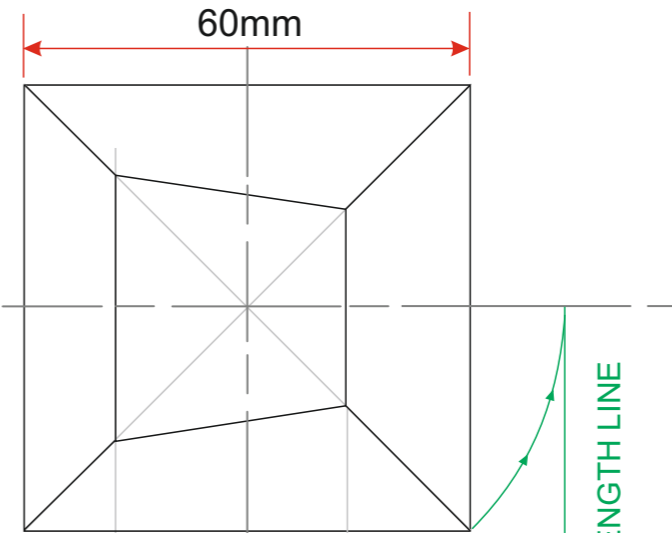

DEVELOPMENTS - CONES

QUESTION

COMPLETE THE DEVELOPMENTS OF THE PLAIN AND TRUNCATED CONES.

PLAIN CONE

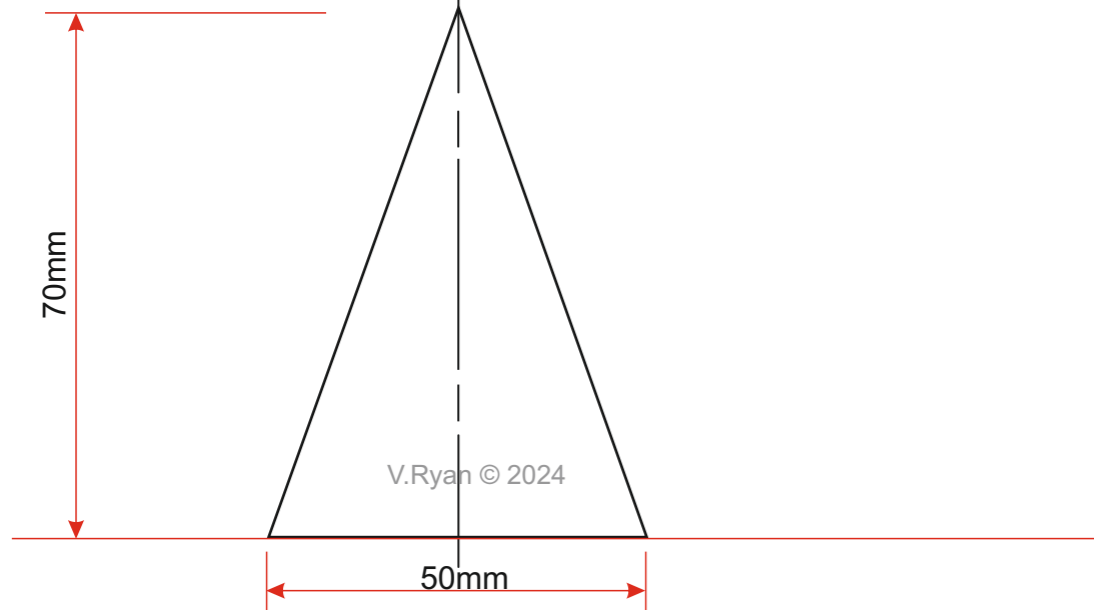
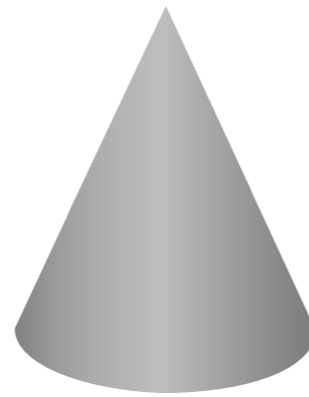
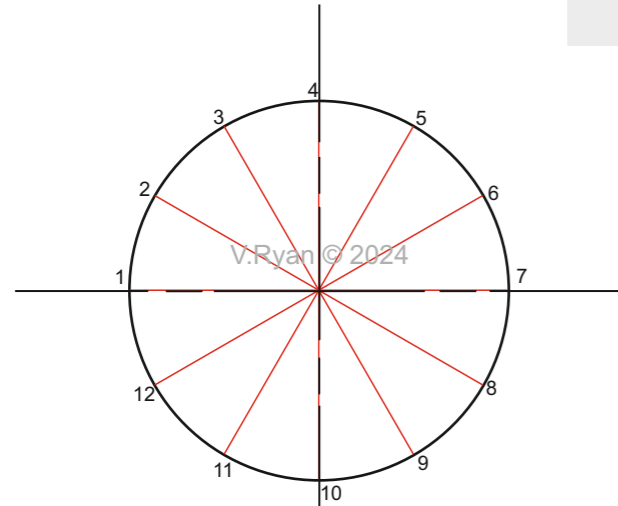

TRUNCATED CONE

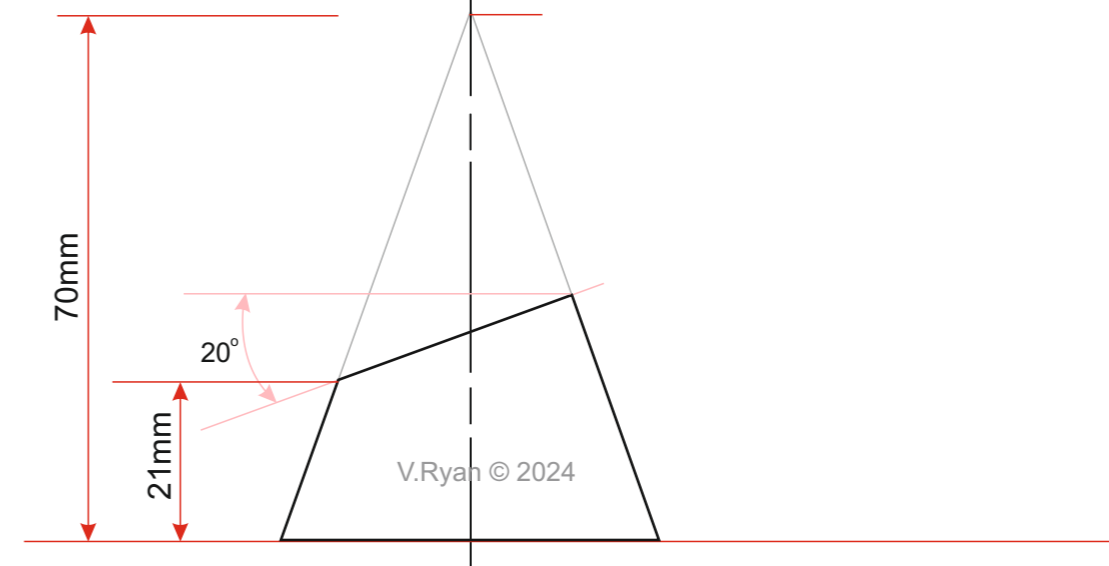
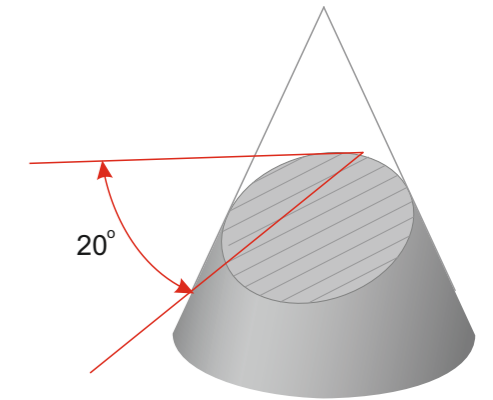
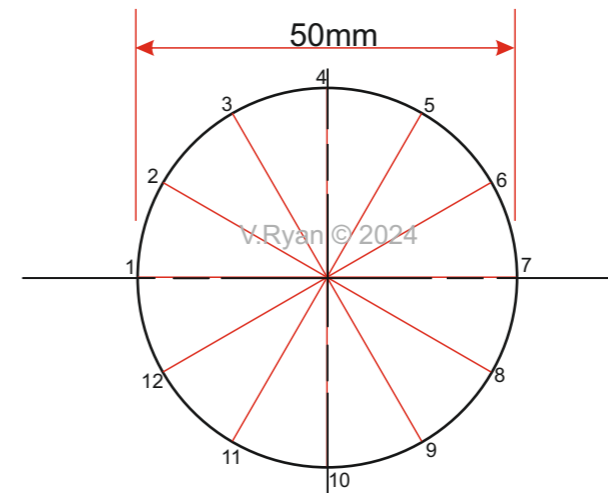

HELPFUL LINK



HELPFUL LINK: https://technologystudent.com/despro_3/develp6.html

DEVELOPMENTS - CURVED SURFACES

QUESTION

HELPFUL LINK



A STRIP OF ALUMINIUM SHEET HAS BEEN CUT TO A TAPERED SHAPE AND FORMED TO A CURVE, AS SHOWN OPPOSITE.

DRAW THE DEVELOPMENT OF THE ALUMINIUM

HELPFUL LINK: https://technologystudent.com/despro_3/develop7.html

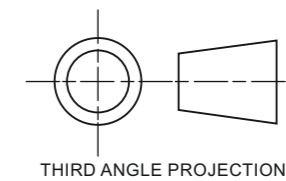
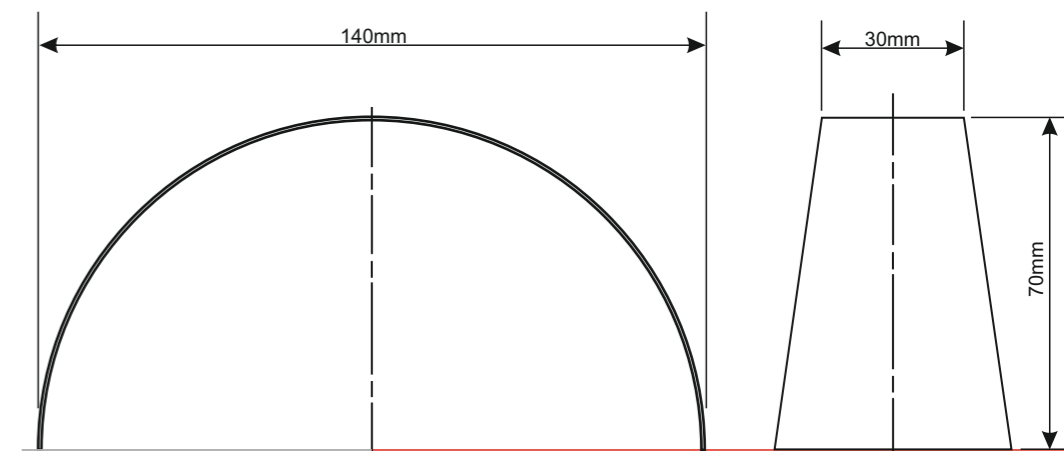
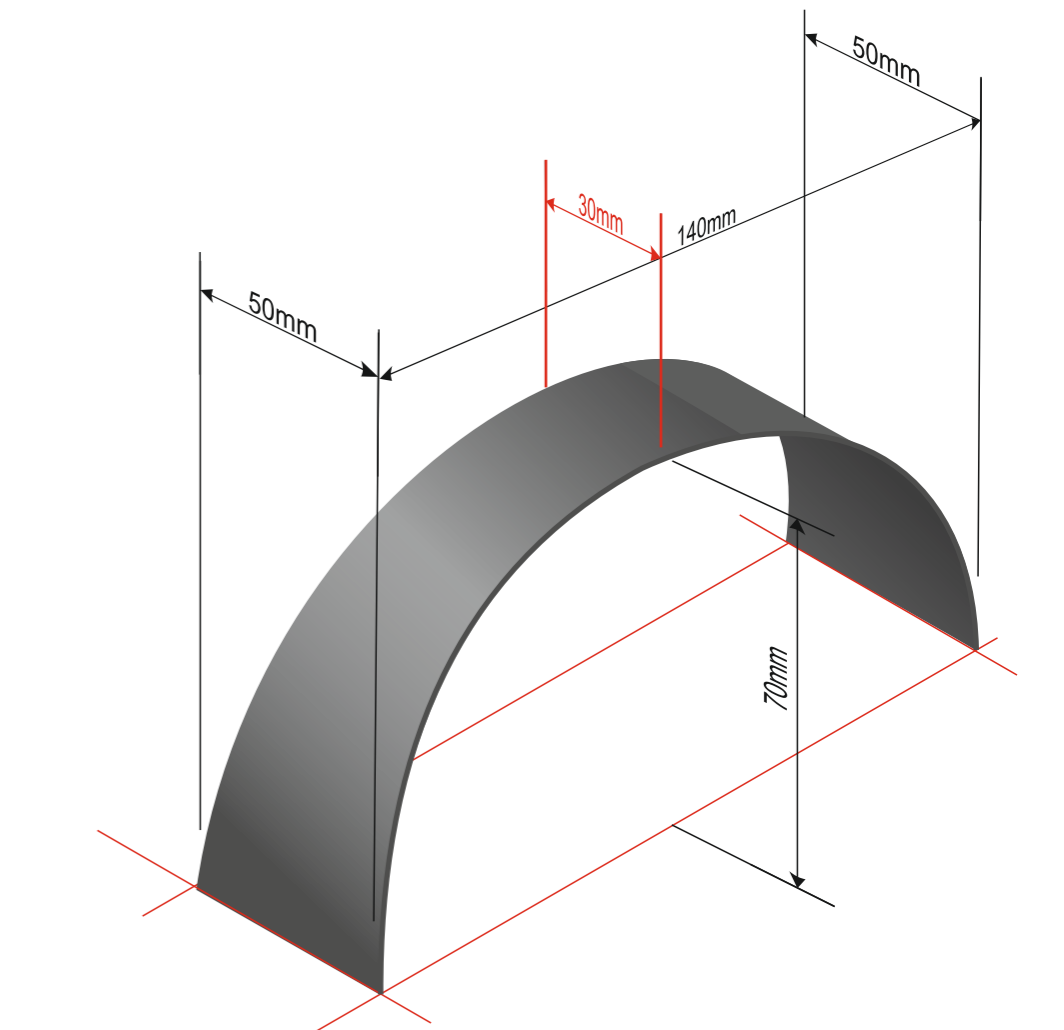
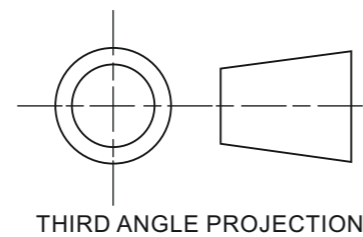
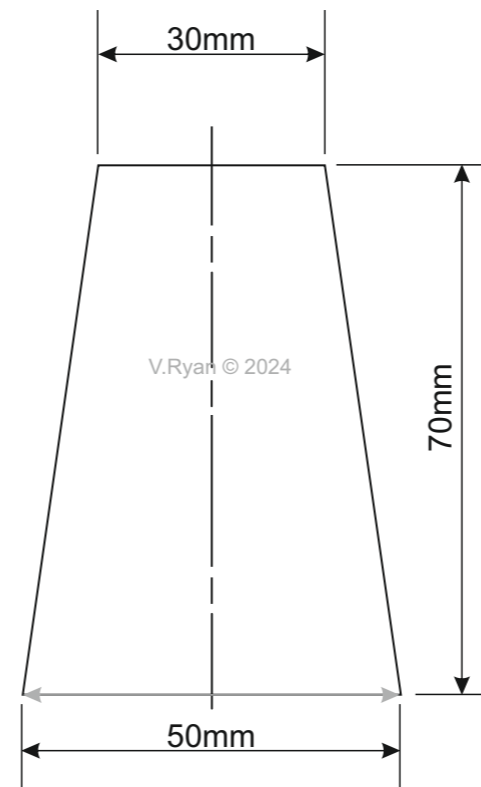
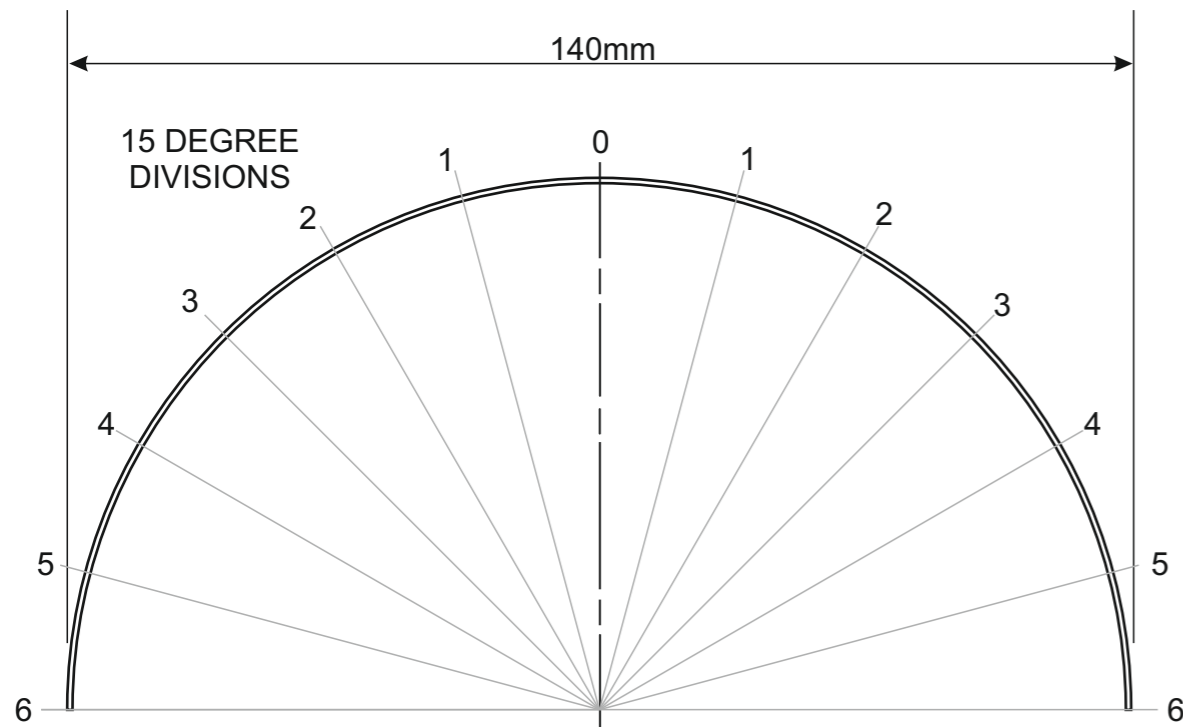

QUESTION

DEVELOPMENTS - HEXAGONAL PYRAMIDS

WORLD ASSOCIATION OF TECHNOLOGY TEACHERS

<https://www.facebook.com/groups/254963448192823/>

technologystudent.com © 2024

V.Ryan © 2024

COMPLETE THE DEVELOPMENT OF THE PLAIN PYRAMID

PLAIN HEXAGONAL PYRAMID

HELPFUL LINK

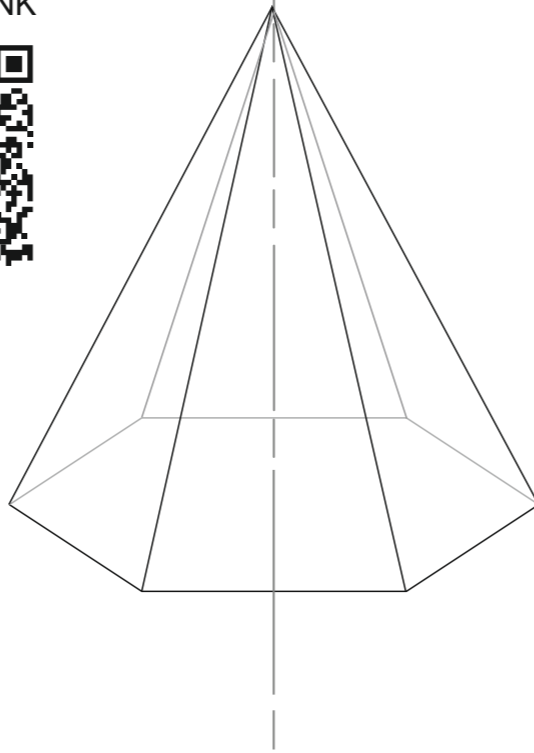
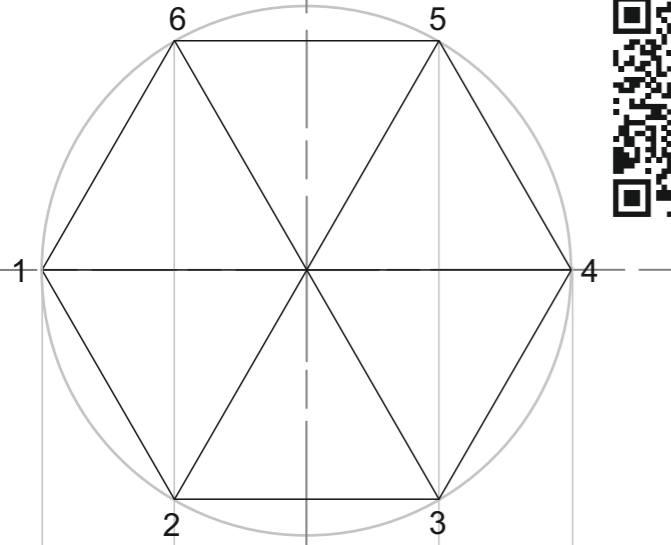

HELPFUL LINK: https://technologystudent.com/despro_3/develop8.html



COMPLETE THE DEVELOPMENT OF THE TRUNCATED PYRAMID

TRUNCATED HEXAGONAL PYRAMID

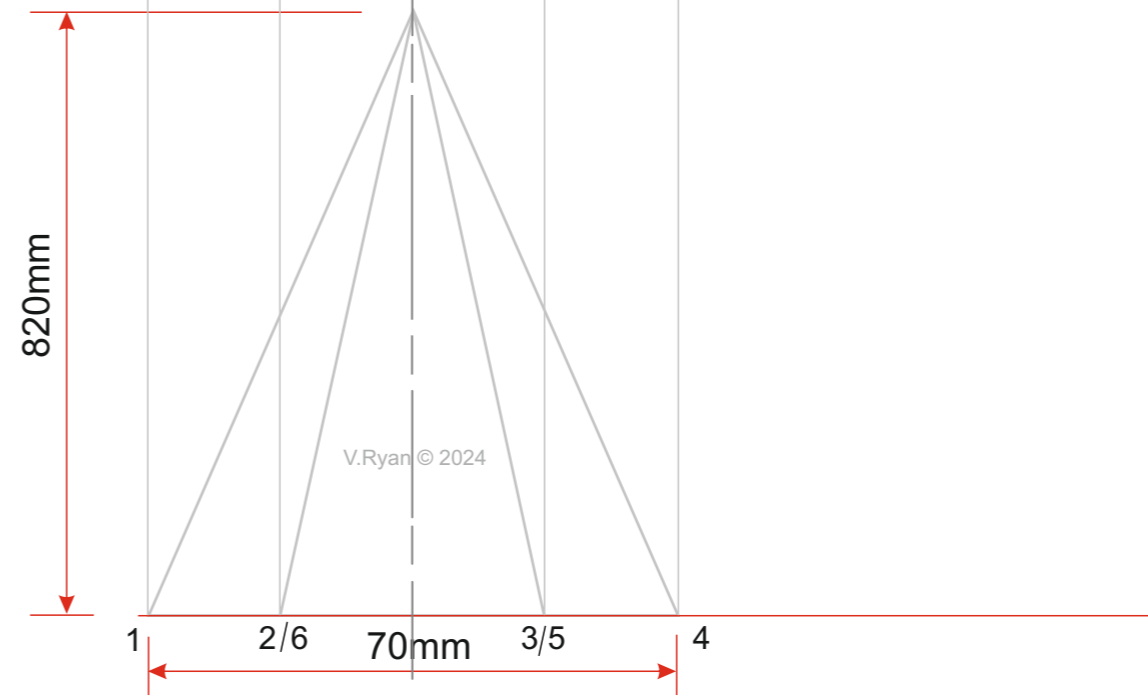
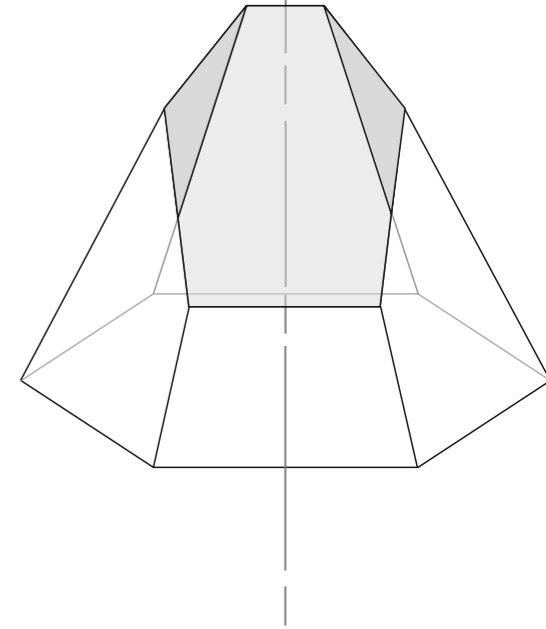
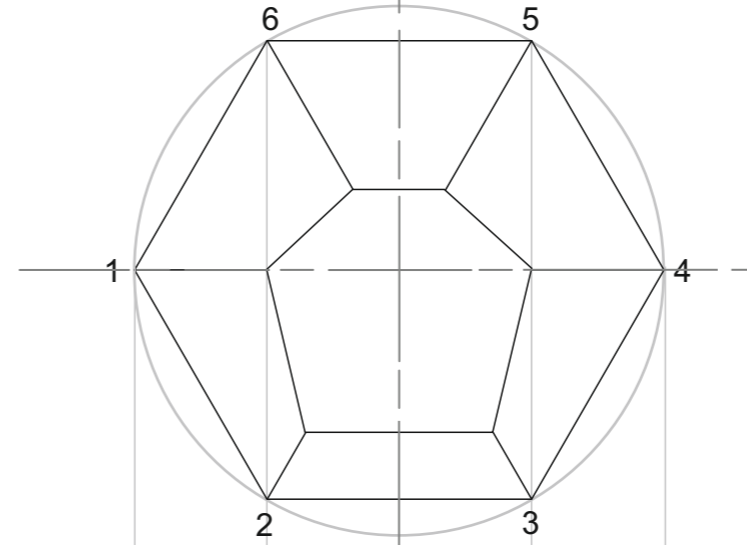

COMPLETE THE DEVELOPMENT OF THE PLAIN PYRAMID (ADD A BASE)

PLAIN HEXAGONAL PYRAMID WITH BASE

HELPFUL LINK



COMPLETE THE DEVELOPMENT OF THE TRUNCATED PYRAMID (ADD A BASE)

TRUNCATED HEXAGONAL PYRAMID WITH BASE

HELPFUL LINK: https://technologystudent.com/despro_3/develop8.html

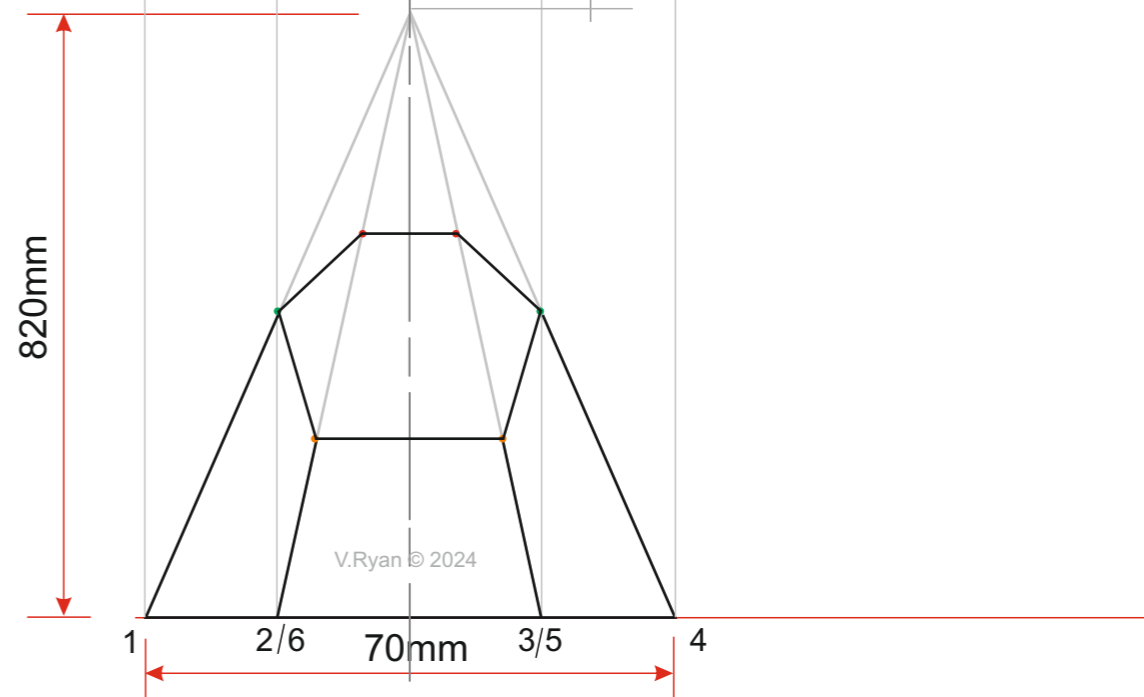
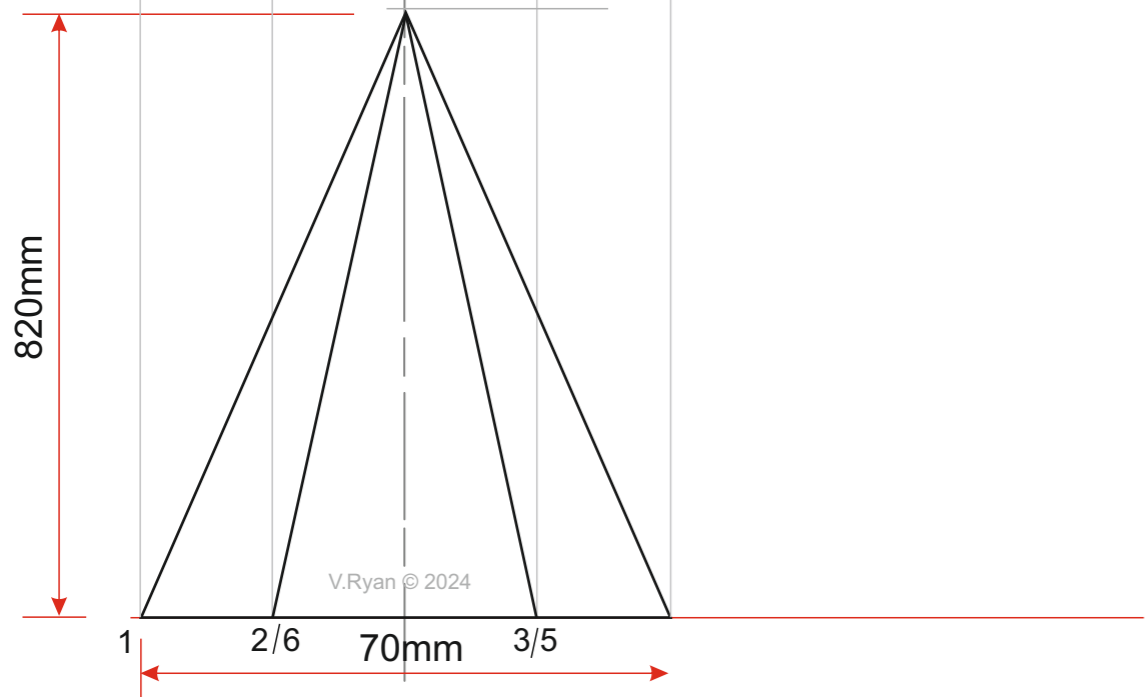
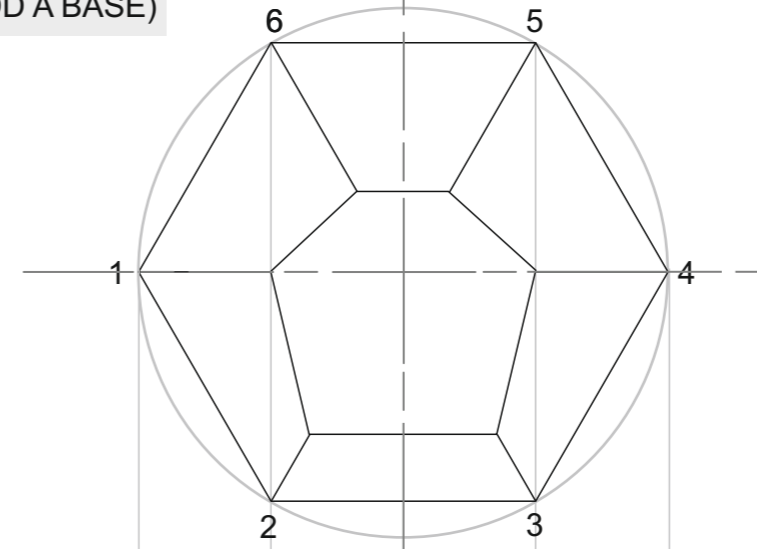
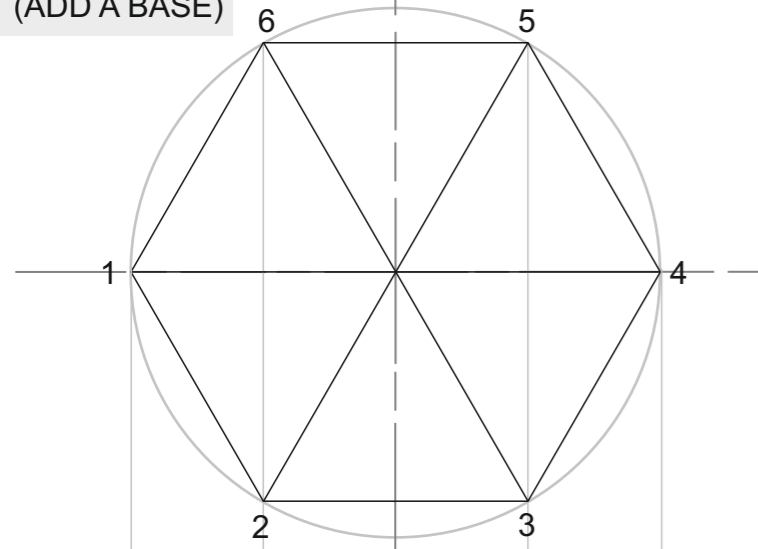

V.Ryan © 2024

V.Ryan © 2024