

# BORING/DRILLING LONG HOLES (DEEP BORING) ON THE LATHE

V.Ryan © 2000 - 2012

On behalf of The World Association of Technology Teachers

## W.A.T.T.

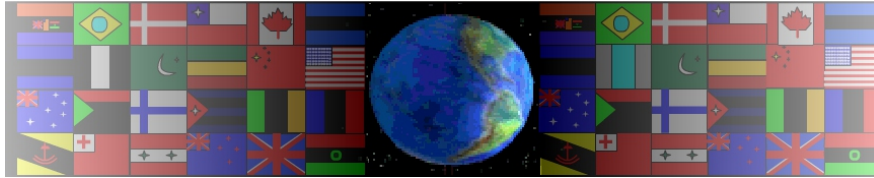

World Association of Technology Teachers

This exercise can be printed and used by teachers and students. It is recommended that you view the website ([www.technologystudent.com](http://www.technologystudent.com)) before attempting the design sheet .

THESE MATERIALS CAN BE PRINTED AND USED BY TEACHERS AND STUDENTS.  
THEY MUST NOT BE EDITED IN ANY WAY OR PLACED ON ANY OTHER MEDIA INCLUDING WEB SITES AND INTRANETS.  
NOT FOR COMMERCIAL USE.  
THIS WORK IS PROTECTED BY COPYRIGHT LAW.  
IT IS ILLEGAL TO DISPLAY THIS WORK ON ANY WEBSITE/MEDIA STORAGE OTHER THAN [www.technologystudent.com](http://www.technologystudent.com)

# BORING/DRILLING LONG HOLES (DEEP BORING) ON THE LATHE

V.Ryan © 2012 World Association of Technology Teachers

1. Why is an auger sometimes a necessity, when using a lathe, in order to drill a long hole?

---

---

2. In the space below, draw/sketch a product that has been 'deep bored', using an auger.

3. By adding notes and by completing the diagram, explain the deep boring process. Label the diagram.

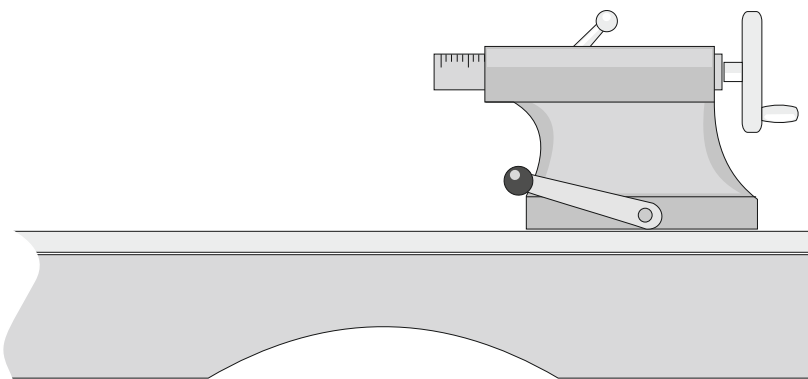

---

---

---

---

---

---