

REVISION WEB - TOOLS

WORLD ASSOCIATION OF TECHNOLOGY TEACHERS <https://www.facebook.com/groups/254963448192823/> www.technologystudent.com © 2017 V.Ryan © 2017

RESEARCH EACH OF THE TOOLS / EQUIPMENT AND WRITE FACTS ON THE REVISION WEB. ADD A SMALL IMAGE(S) FOR EACH OF THE TOOLS / EQUIPMENT. AN EXAMPLE HAS BEEN COMPLETED FOR YOU.

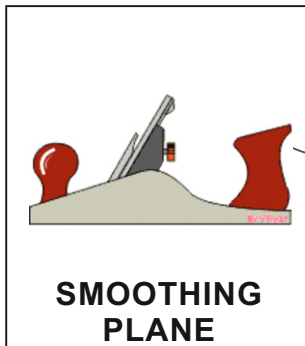
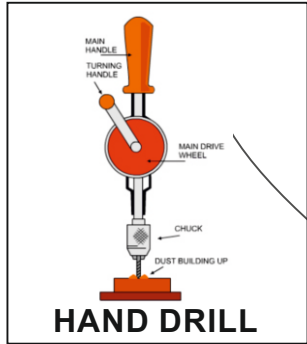

PREPARING A LENGTH OF WOOD FOR LEVELLING A SURFACE
SMOOTHING WOOD
FACE SIDE / FACE EDGE

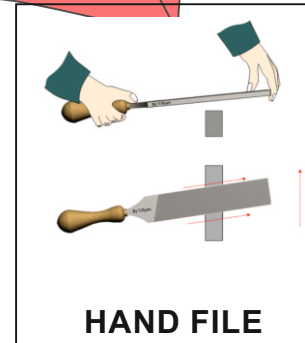
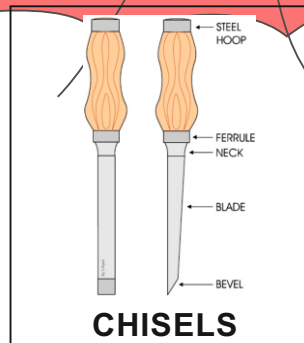
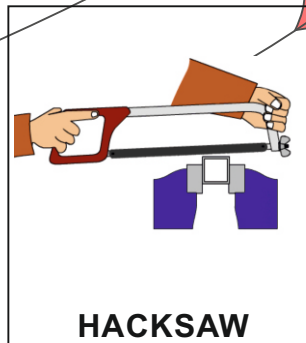
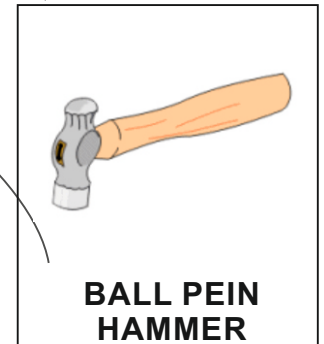
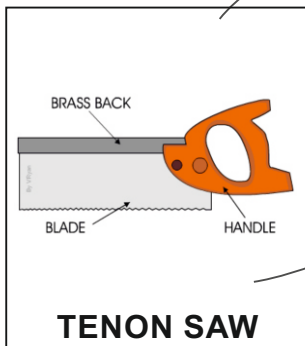
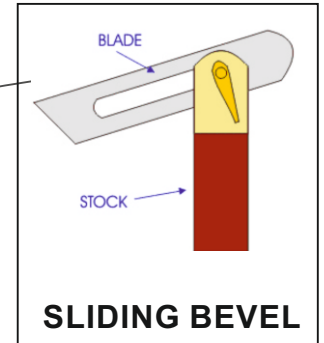

REVISION WEB - MANUFACTURING PROCESSES

WORLD ASSOCIATION OF TECHNOLOGY TEACHERS <https://www.facebook.com/groups/254963448192823/> www.technologystudent.com © 2017 V.Ryan © 2017
 RESEARCH EACH OF THE MANUFACTURING PROCESSES. WRITE FACTS ON THE REVISION WEB. YOU CAN ADD A SMALL IMAGE(S) FOR EACH OF THE PROCESSES. AN EXAMPLE HAS BEEN COMPLETED FOR YOU.



GALVANISING STEEL



CNC ROUTER

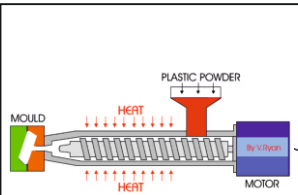

INJECTION MOULDING

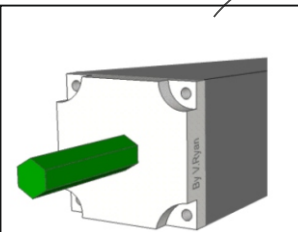

EXTRUSION

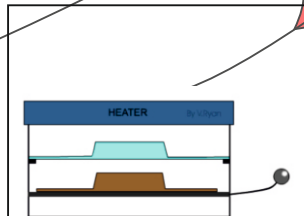

VACUUM FORMING

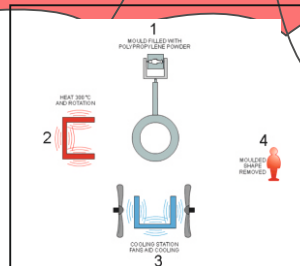

ROTATIONAL MOULDING

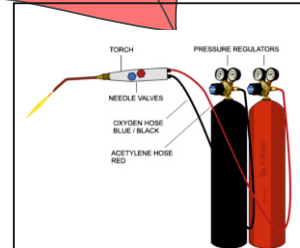

OXYACETYLENE WELDING



LASER CUTTER



3D PRINTER

CAM - COMPUTER AIDED MANUFACTURE
CONTROLLED BY COMPUTER
LINKS TO CAD SOFTWARE
CUTS ACCURATE SHAPES USUALLY IN 'WOOD'

REVISION WEB - PRINTING PROCESSES

WORLD ASSOCIATION OF TECHNOLOGY TEACHERS <https://www.facebook.com/groups/254963448192823/> www.technologystudent.com © 2017 V.Ryan © 2017

RESEARCH EACH OF THE PRINTING PROCESSES. WRITE FACTS ON THE REVISION WEB.
CONSIDER ADDING AN IMAGE(S). AN EXAMPLE HAS BEEN COMPLETED FOR YOU.

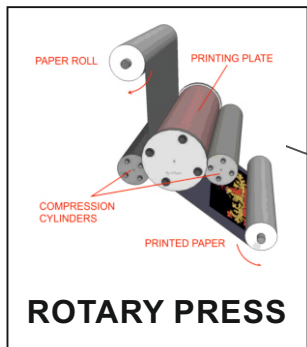
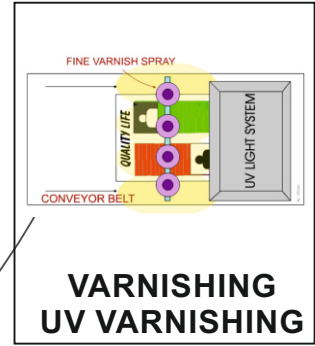
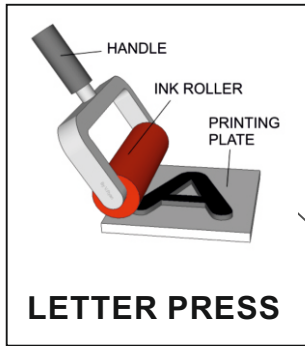

**COMMERCIAL PRINTING
FAST WHEN VOLUME PRINTING
PAPER PRODUCTS SUCH AS
WALLPAPER AND FABRICS**

