

# WORKSHOP EQUIPMENT / TOOLS - 'BOXED LEARNING' EXERCISE

1

WRITE A BRIEF DESCRIPTION OF A DISK SANDER (seen opposite)

---

---

---

---

---

---

---

---

## THE DISK SANDER

LABEL THE PARTS OF THE DISK SANDER

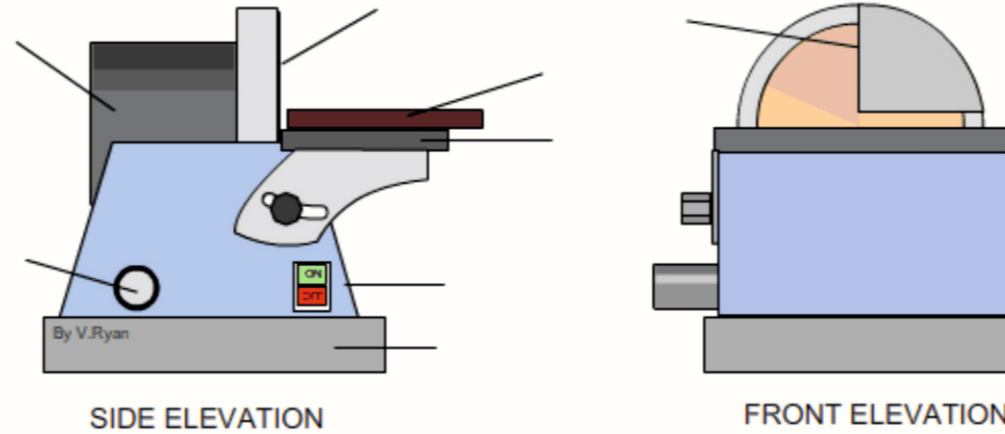

5

HOW CAN AN ANGLE BE SANDED ON THE EDGE OF A PIECE OF MATERIAL?  
(Include a sketch)

---

---

---

---

---

---

---

---

2

'USING THE DISK SANDER'. CAREFULLY STUDY THE IMAGE  
(Then go to 3)

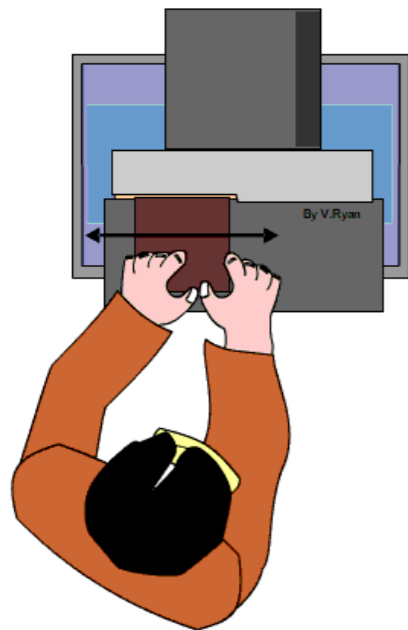

3

USING THE IMAGE IN 2 FOR REFERENCE, DESCRIBE THE TYPICAL USE OF A DISK SANDER  
(Add labels to the image, if this helps you describe its use)

---

---

---

---

---

---

---

---

4

LIST SAFETY FACTORS THAT APPLY TO THIS MACHINE

---

---

---

---

---

---

---

---

ESSENTIAL LINKS:

[http://www.technologystudent.com/equip\\_flash/disk1.html](http://www.technologystudent.com/equip_flash/disk1.html)  
<https://www.youtube.com/watch?v=8vQnbFJytmQ>