

# THE COMBINATION DISC AND BELT SANDER - EXAMINATION QUESTIONS

HELPFUL LINK: [https://technologystudent.com/equip\\_flash/combsander1.html](https://technologystudent.com/equip_flash/combsander1.html)

1. Briefly describe the function / purpose of the Combination disc and belt sander.  
**4 marks**

---

---

---

---

---

2. Label the parts of the combination disc / belt sander, identified by the arrows.  
**5 marks**

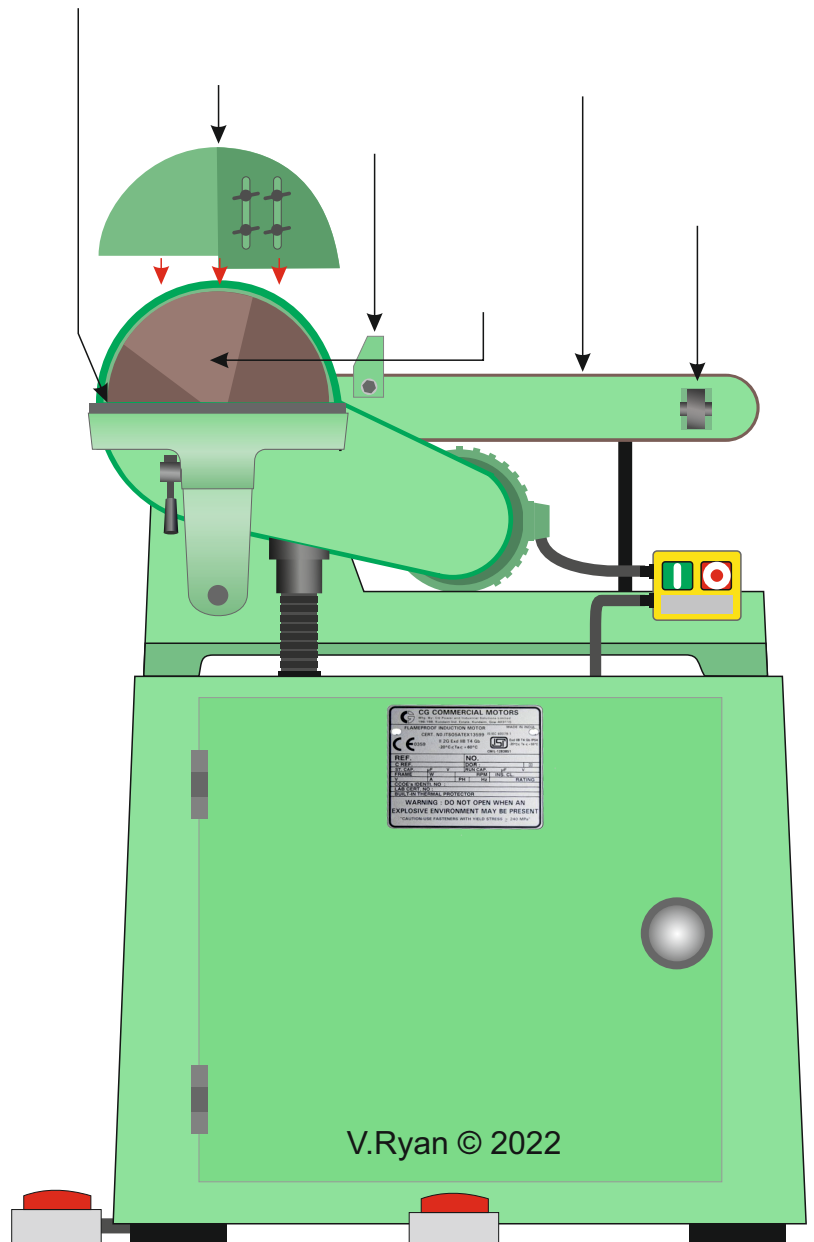

# THE COMBINATION DISC AND BELT SANDER - EXAMINATION QUESTIONS

HELPFUL LINK: [https://technologystudent.com/equip\\_flash/combsander1.html](https://technologystudent.com/equip_flash/combsander1.html)

3. Briefly describe how the Roller End of the belt sander can be used. (Include a sketch or paste an image, to support your answer). **4 marks**

---

---

---

4. Briefly describe how the 'Flat' portion of the belt sander is used. (Include a sketch or paste an image, to support your answer). **4 marks**

---

---

---

# THE COMBINATION DISC AND BELT SANDER - EXAMINATION QUESTIONS

HELPFUL LINK: [https://technologystudent.com/equip\\_flash/combsander1.html](https://technologystudent.com/equip_flash/combsander1.html)

5. What is dust extraction? Why is dust extraction vital on this machine? **4 marks**

---

---

---

---

6. Paste two images of suitable 'dust' face masks, that can also be worn, when using the disc / belt sander. Why are they important? **4 marks**

---

---

---

---

7. Paste two images of the two adjustable guards (or sketch the guards). What is their function and why are they important? **6 marks**

---

---

---

---

---

---

---

---