

# THE CENTRE LATHE

V.Ryan © 2000 - 2009

On behalf of The World Association of Technology Teachers

## W.A.T.T.

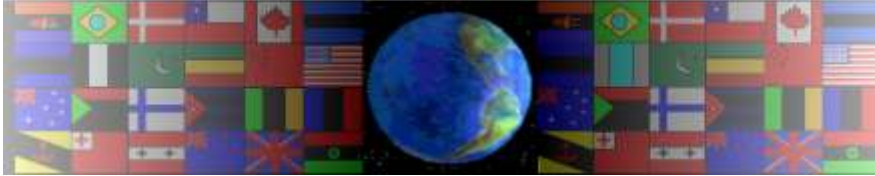

World Association of Technology Teachers

This exercise can be printed and used by teachers and students. It is recommended that you view the website ([www.technologystudent.com](http://www.technologystudent.com)) before attempting the design sheet .

THESE MATERIALS CAN BE PRINTED AND USED BY TEACHERS AND STUDENTS.  
THEY MUST NOT BE EDITED IN ANY WAY OR PLACED ON ANY OTHER MEDIA INCLUDING WEB SITES AND INTRANETS.  
NOT FOR COMMERCIAL USE.  
THIS WORK IS PROTECTED BY COPYRIGHT LAW.  
IT IS ILLEGAL TO DISPLAY THIS WORK ON ANY WEBSITE/MEDIA STORAGE OTHER THAN [www.technologystudent.com](http://www.technologystudent.com)

# DRILLING WITH THE CENTRE LATHE

V.Ryan © 2009 World Association of Technology Teachers

1. The centre lathe can be used to drill accurately if a suitable attachment called a drill chuck, is correctly fitted. In the space below draw a suitable drill chuck, for use with a centre lathe. Add labels to your drawing.

2. Identify the morse taper shaft on your drawing (above) and explain its purpose.

---

---

3. The drawing below is incomplete as the drill chuck is missing. Draw a typical drill chuck in the correct position.

CHUCK

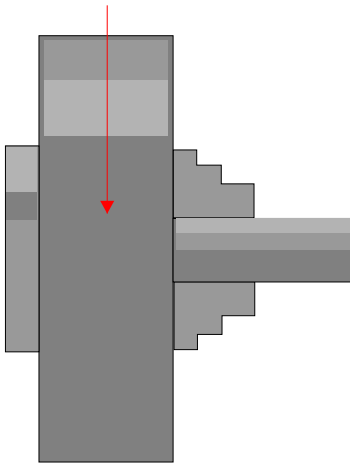

TAILSTOCK

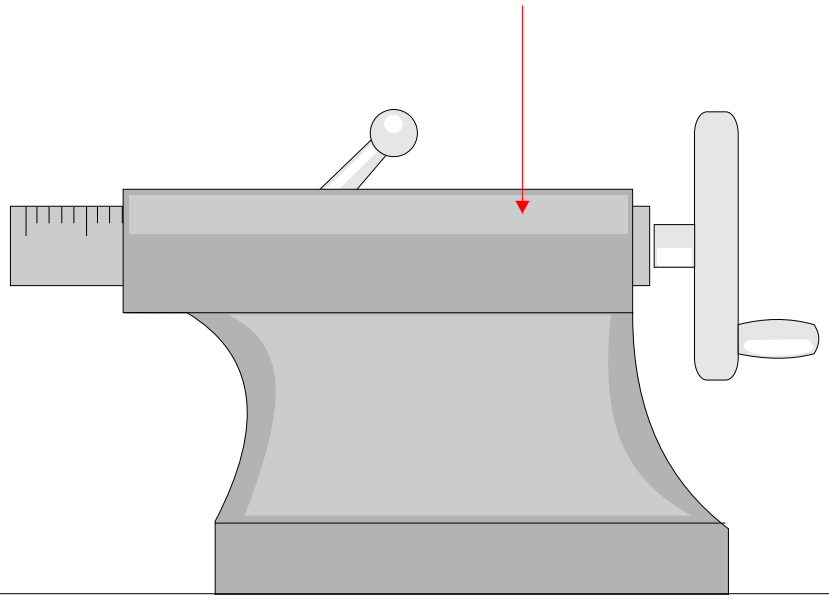

4. A typical centre drill is shown opposite. Describe two techniques that require its use.

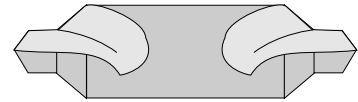

COUNTERSINK  
BIT

TECHNIQUE ONE:

---

---

TECHNIQUE TWO:

---

---

5. Why is there a need to apply soluble oil when drilling?

---

---