

# COMPRESSION MOULDING

V.Ryan © 2000 - 2011

On behalf of The World Association of Technology Teachers

## W.A.T.T.

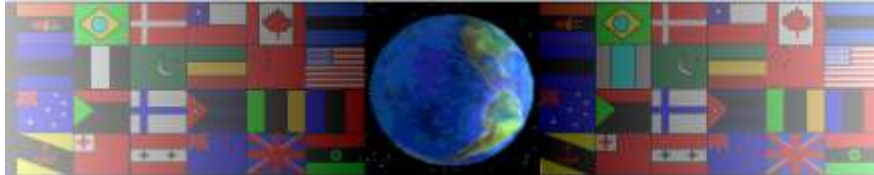

World Association of Technology Teachers

This exercise can be printed and used by teachers and students. It is recommended that you view the website ([www.technologystudent.com](http://www.technologystudent.com)) before attempting the design sheet .

THESE MATERIALS CAN BE PRINTED AND USED BY TEACHERS AND STUDENTS.  
THEY MUST NOT BE EDITED IN ANY WAY OR PLACED ON ANY OTHER MEDIA INCLUDING WEB SITES AND INTRANETS.  
NOT FOR COMMERCIAL USE.  
THIS WORK IS PROTECTED BY COPYRIGHT LAW.  
IT IS ILLEGAL TO DISPLAY THIS WORK ON ANY WEBSITE/MEDIA STORAGE OTHER THAN [www.technologystudent.com](http://www.technologystudent.com)

# COMPRESSION MOULDING

V.Ryan © 2011 World Association of Technology Teachers

The diagrams below show the stages in the manufacture of the MP3 station casing, through a process called Compression Moulding. complete the sheet by adding notes underneath each stage.

*Each side of the casing is manufactured through the process of compression moulding.*

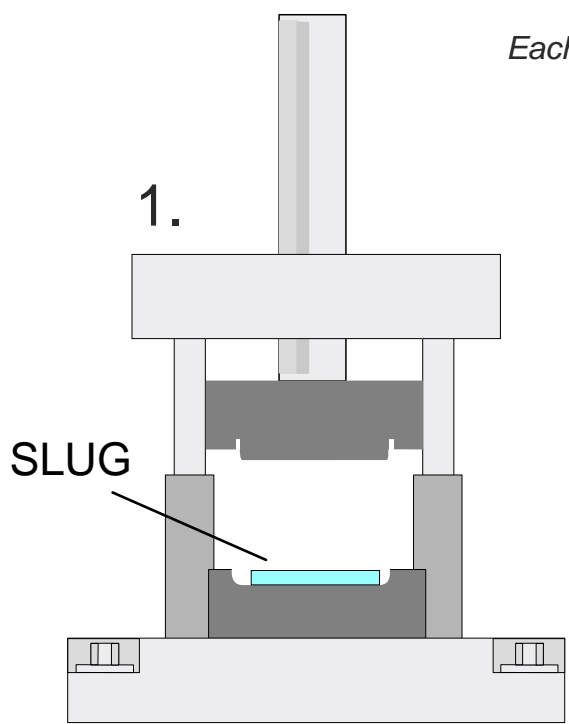

---

---

---

---

---

---

---

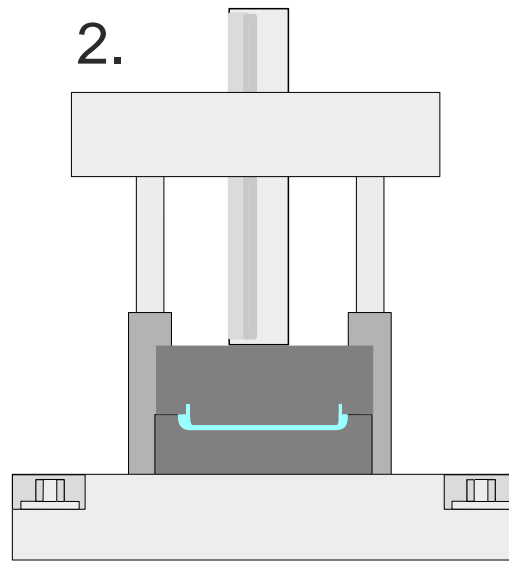

---

---

---

---

---

---

---

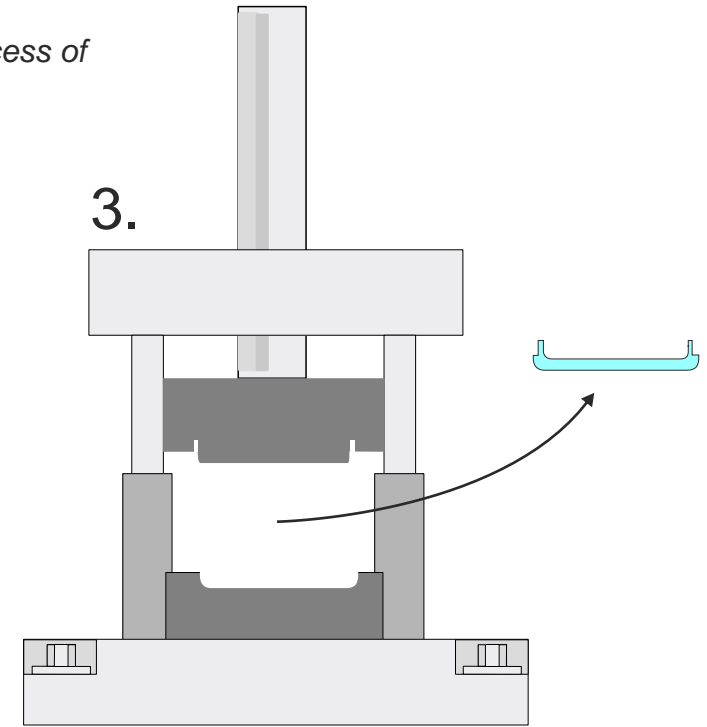

---

---

---

---

---

---

---