

WOOD TURNING BETWEEN CENTRES

V.Ryan © 2000 - 2012

On behalf of The World Association of Technology Teachers

W.A.T.T.



World Association of Technology Teachers

This exercise can be printed and used by teachers and students. It is recommended that you view the website (www.technologystudent.com) before attempting the design sheet .

THESE MATERIALS CAN BE PRINTED AND USED BY TEACHERS AND STUDENTS.
THEY MUST NOT BE EDITED IN ANY WAY OR PLACED ON ANY OTHER MEDIA INCLUDING WEB SITES AND INTRANETS.
NOT FOR COMMERCIAL USE.
THIS WORK IS PROTECTED BY COPYRIGHT LAW.
IT IS ILLEGAL TO DISPLAY THIS WORK ON ANY WEBSITE/MEDIA STORAGE OTHER THAN www.technologystudent.com

WOOD TURNING BETWEEN CENTRES

V.Ryan © 2012 World Association of Technology Teachers

1. Sketch a dead centre and live centre. Explain the difference between both.

DEAD CENTRE

LIVE CENTRE



DIFFERENCE:

2. Sketch a typical turned product, set between the drive centre and dead centre of the lathe, drawn below.

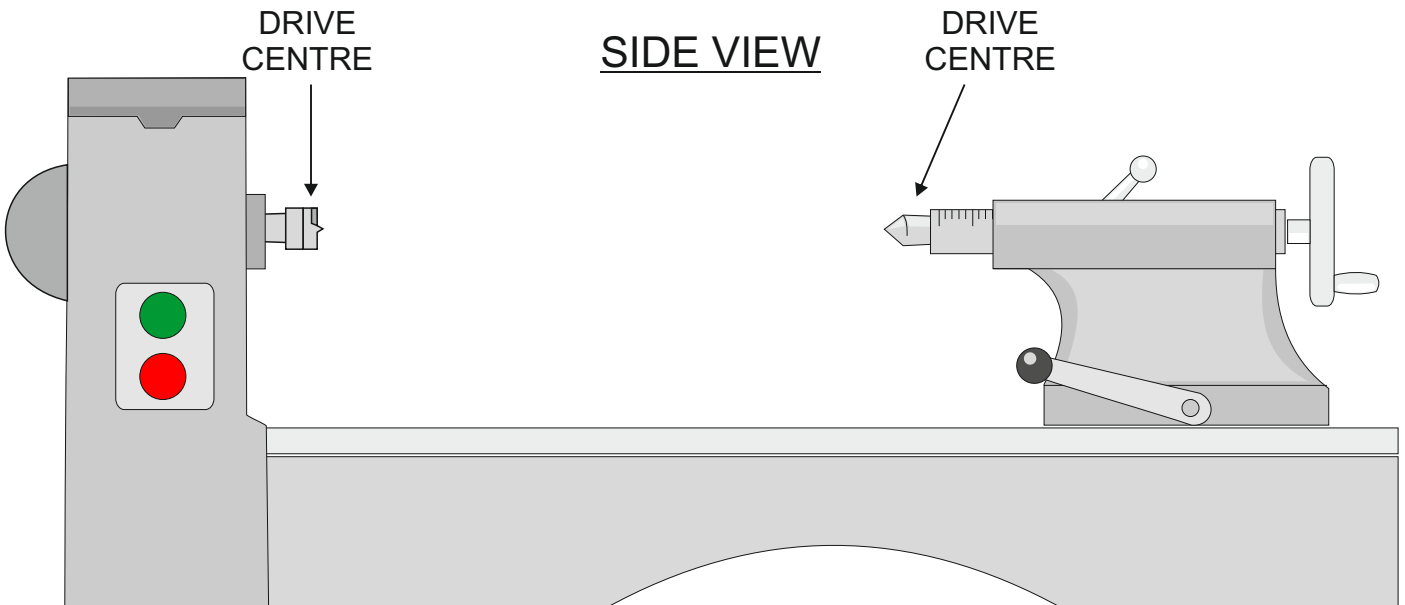

3. Describe the type of turning that can be carried out using a three or four jaw chuck. Emphasise how safety is the overriding factor. Include a simple sketch to help support your answer..

SKETCH
