

TECHNICAL INSTRUCTION SHEETS

WORLD ASSOCIATION OF TECHNOLOGY TEACHERS

<https://www.facebook.com/groups/254963448192823/>

www.technologystudent.com © 2017

MARKING OUT AND CUTTING:

FINGER JOINTS

and

BRIDLE JOINTS

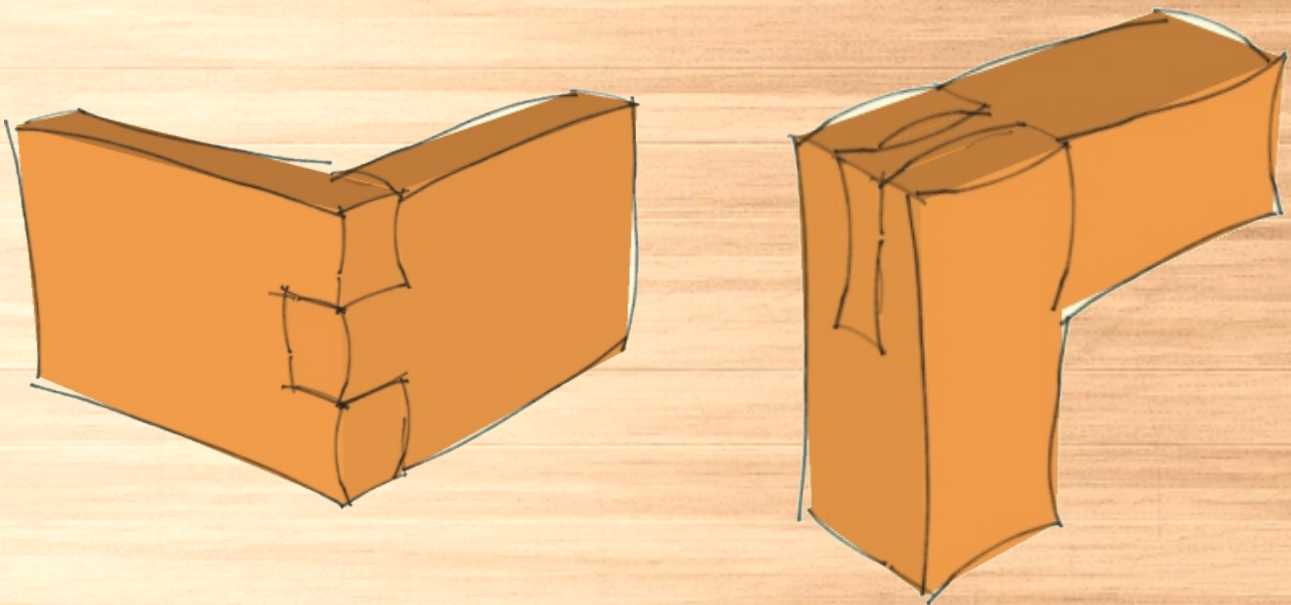

FINGER JOINTS

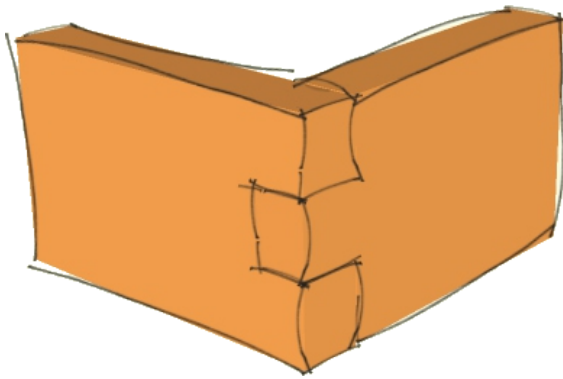

- ① Use glass paper to remove any rough edge, from both pieces of wood.

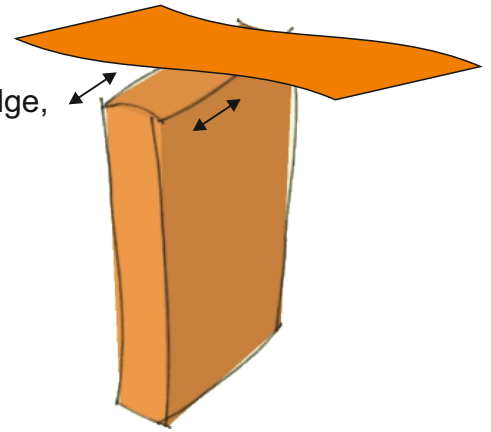

Mark out on both pieces of wood.

②

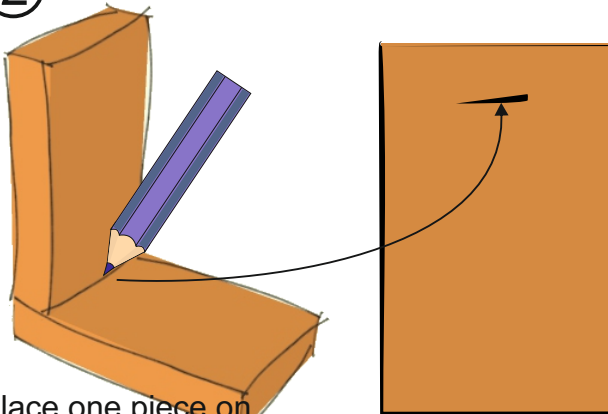

Place one piece on the edge of the second and mark the thickness of the wood.

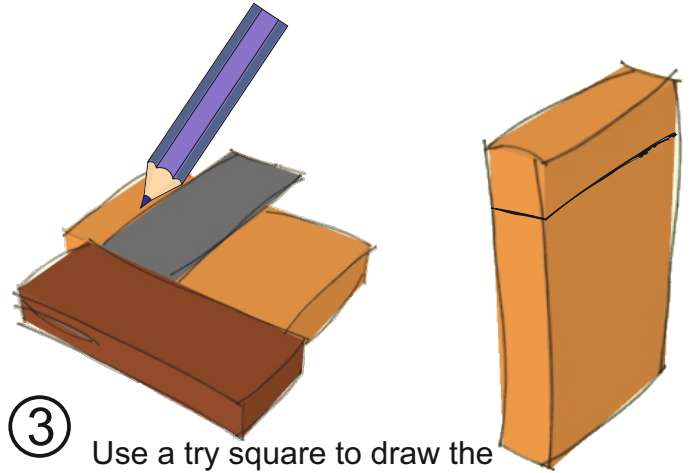

③

Use a try square to draw the 'thickness' accurately around both pieces of wood.

Mark out one piece of wood this way.

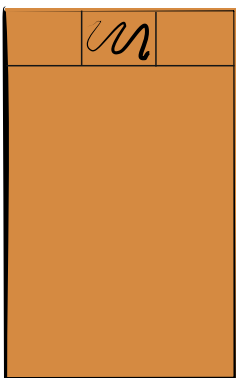

④

Divide the edge of one piece as soon in the diagram. Shade the waste wood.

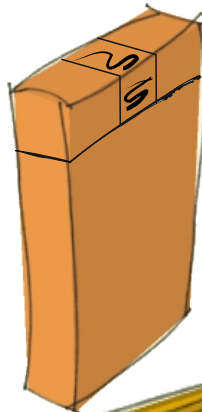

⑤

Draw the lines over the top and down the back of the wood.

⑥

Using a tenon saw to cut down the vertical lines, to the horizontal line. Keep on the waste side of the pencil lines.

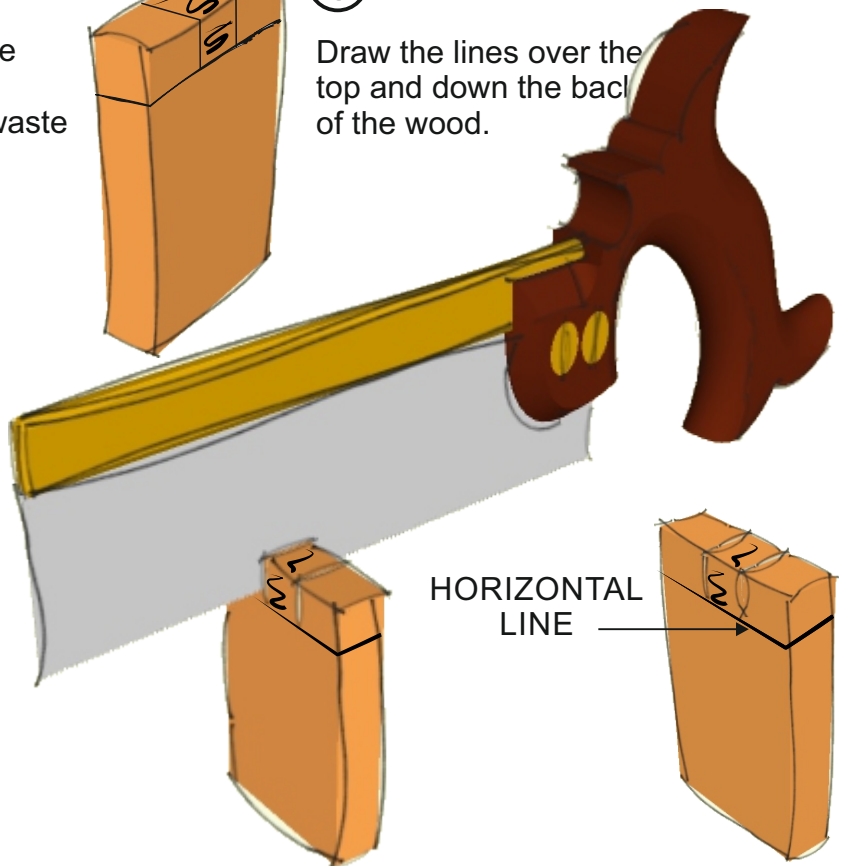

HORIZONTAL LINE

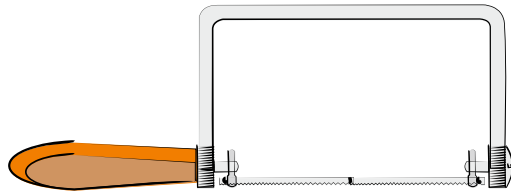
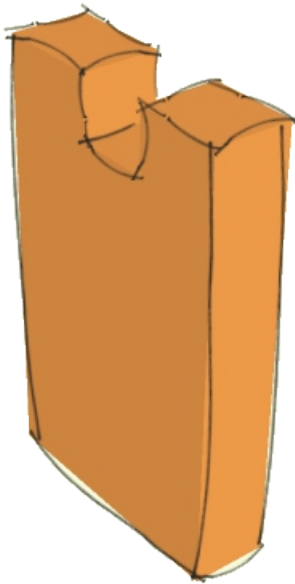

⑦

Cut away the waste using a coping saw. Sometimes a fretsaw can be used very accurately. Do not cut below the horizontal line.

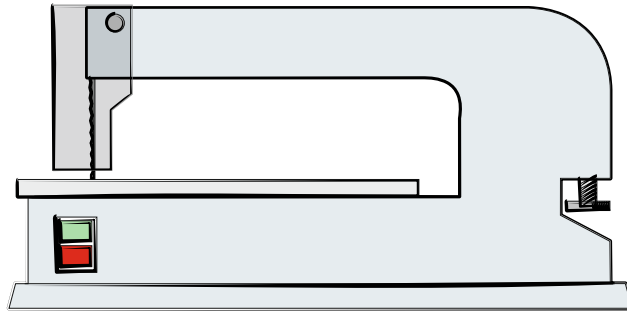

Mark the second piece of wood this way.

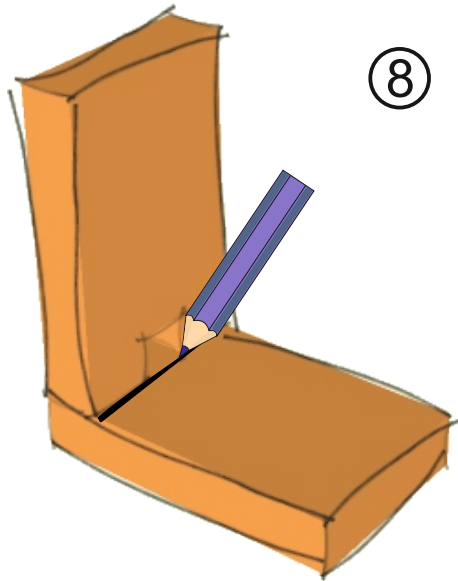
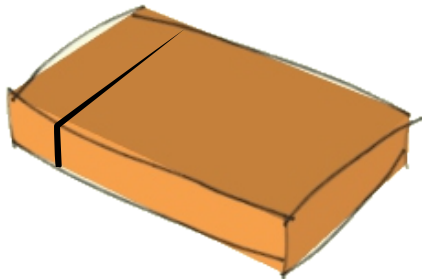
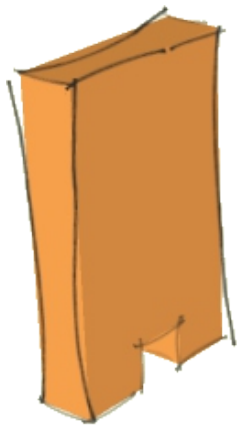

⑧

Place the first jointed piece on the edge of the second piece. Draw the outline of the joint with a pencil.

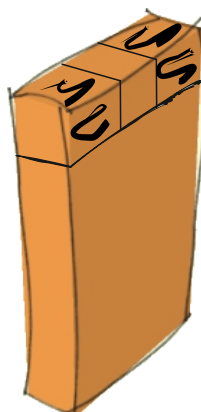
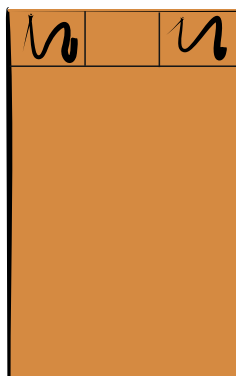

⑨

Using a try square draw the lines across the top of the second piece and down the back. Shade the waste wood.

- ⑩ Use a tenon saw to cut down the vertical lines, keeping on the waste side of the lines.

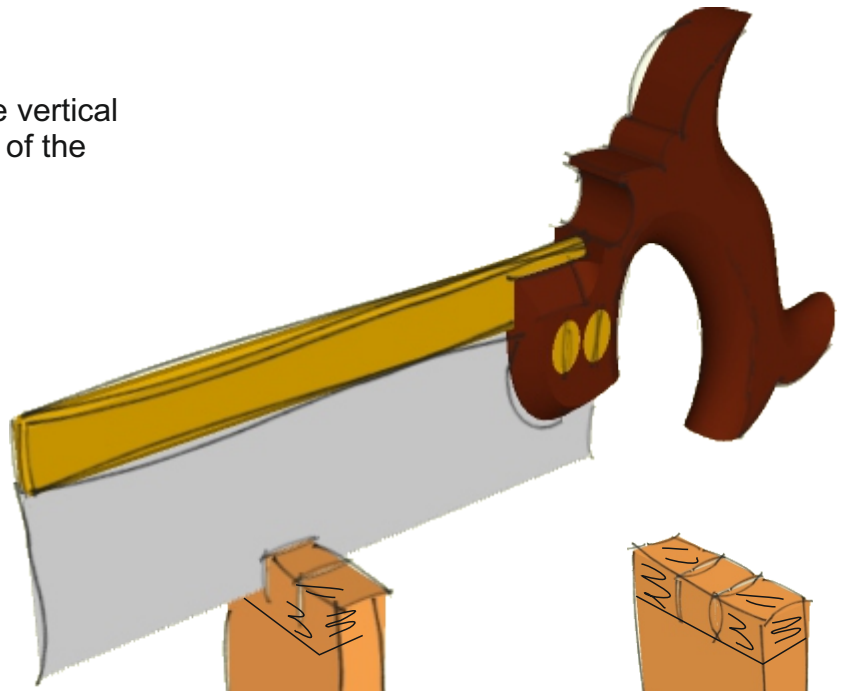

- ⑪ Turn the wood around in the vice and cut down the last set of lines, producing this joint.

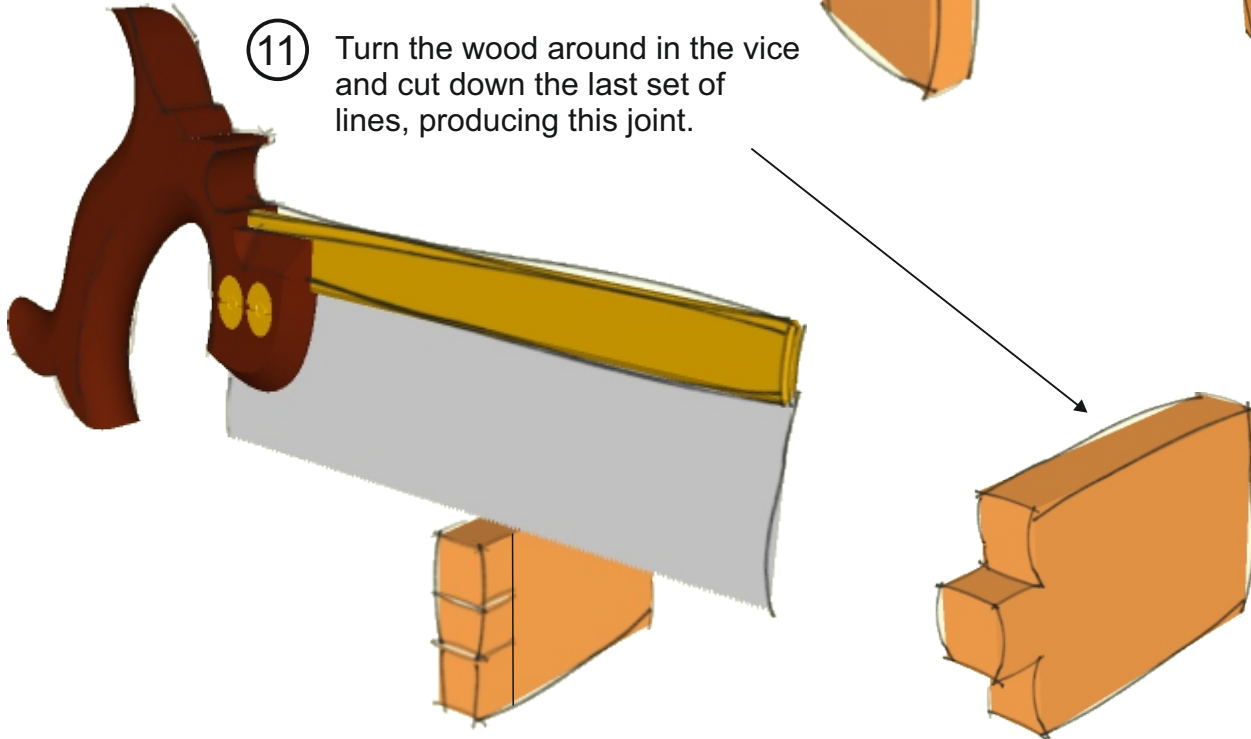

- ⑫ Fit the joint, as shown in the diagram.

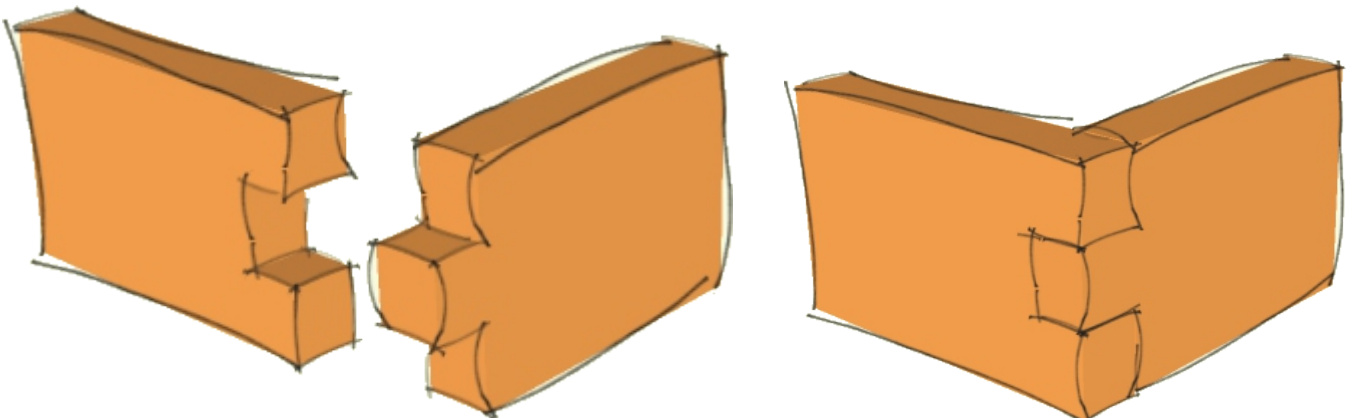

BRIDLE JOINTS

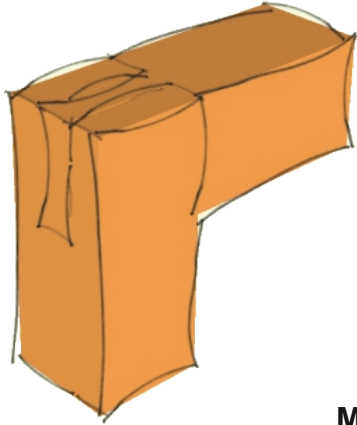

① Use glass paper to remove any rough edge, from both pieces of wood.

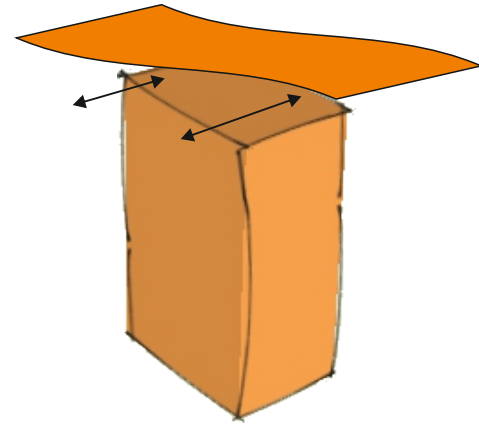

②

Mark out on both pieces of wood.

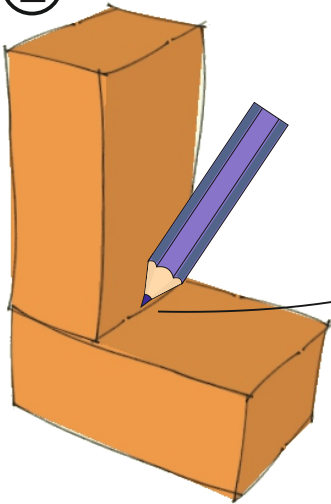

Place one piece on the edge of the second and mark the thickness of the wood.

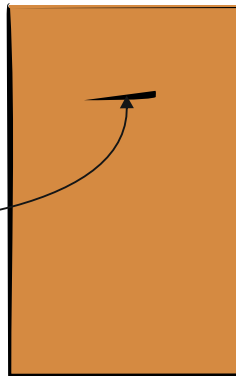

③ Use a try square to draw the 'thickness' accurately around both pieces of wood.

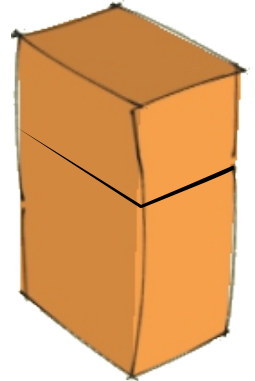

Mark out one piece of wood this way.

WORLD ASSOCIATION OF TECHNOLOGY TEACHERS

<https://www.facebook.com/groups/254963448192823/>

www.technologystudent.com © 2017

④

Divide the edge of one piece as soon in the diagram. Shade the waste wood.

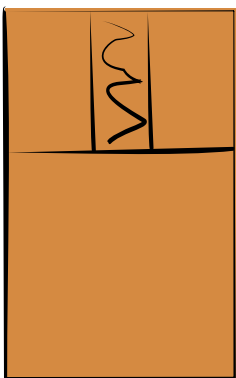

⑤

Draw the lines over the top and down the back of the wood.

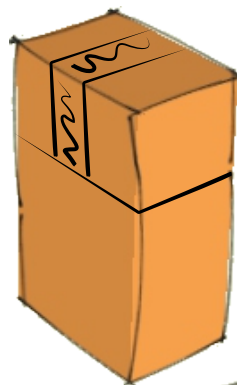

⑥

Using a tenon saw to cut down the vertical lines, to the horizontal line. Keep on the waste side of the pencil lines.

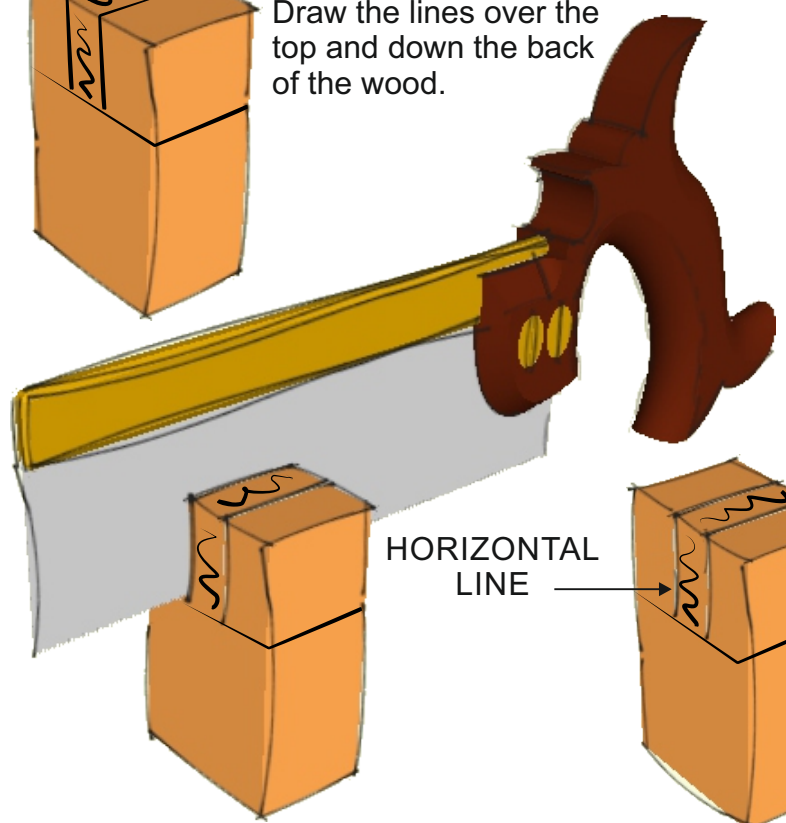

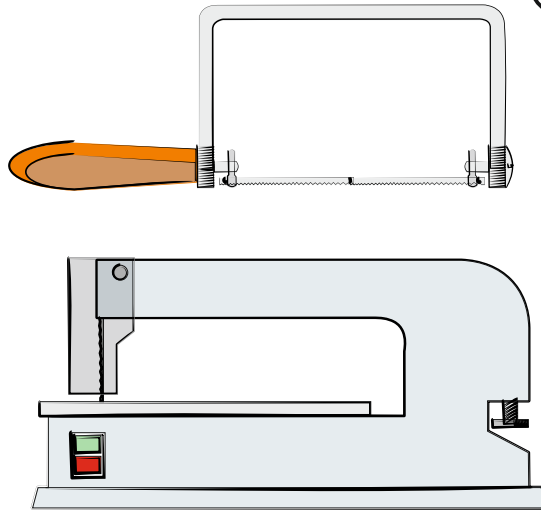
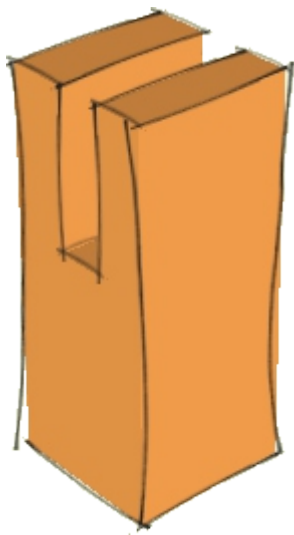

7

Cut away the waste using a coping saw. Sometimes a fretsaw can be used very accurately. Do not cut below the horizontal line.

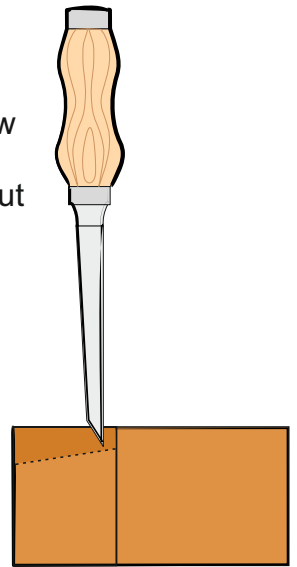

Mark the second piece of wood this way.

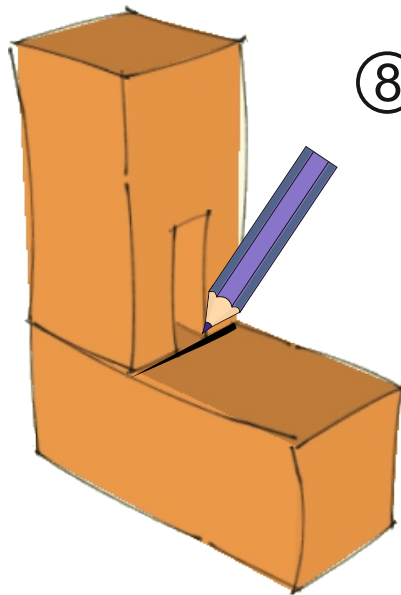
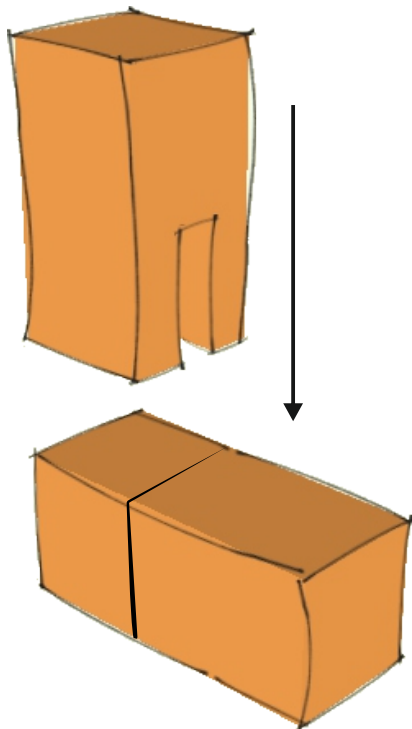

8

Place the first jointed piece on the edge of the second piece. Draw the outline of the joint with a pencil.

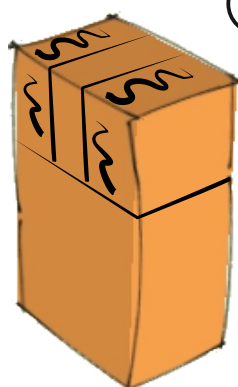
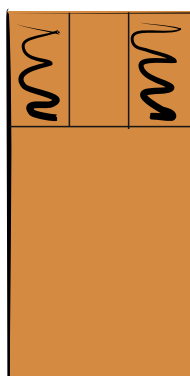

9

Using a try square draw the lines across the top of the second piece and down the back. Shade the waste wood.

- 10 Use a tenon saw to cut down the vertical lines, keeping on the waste side of the lines.

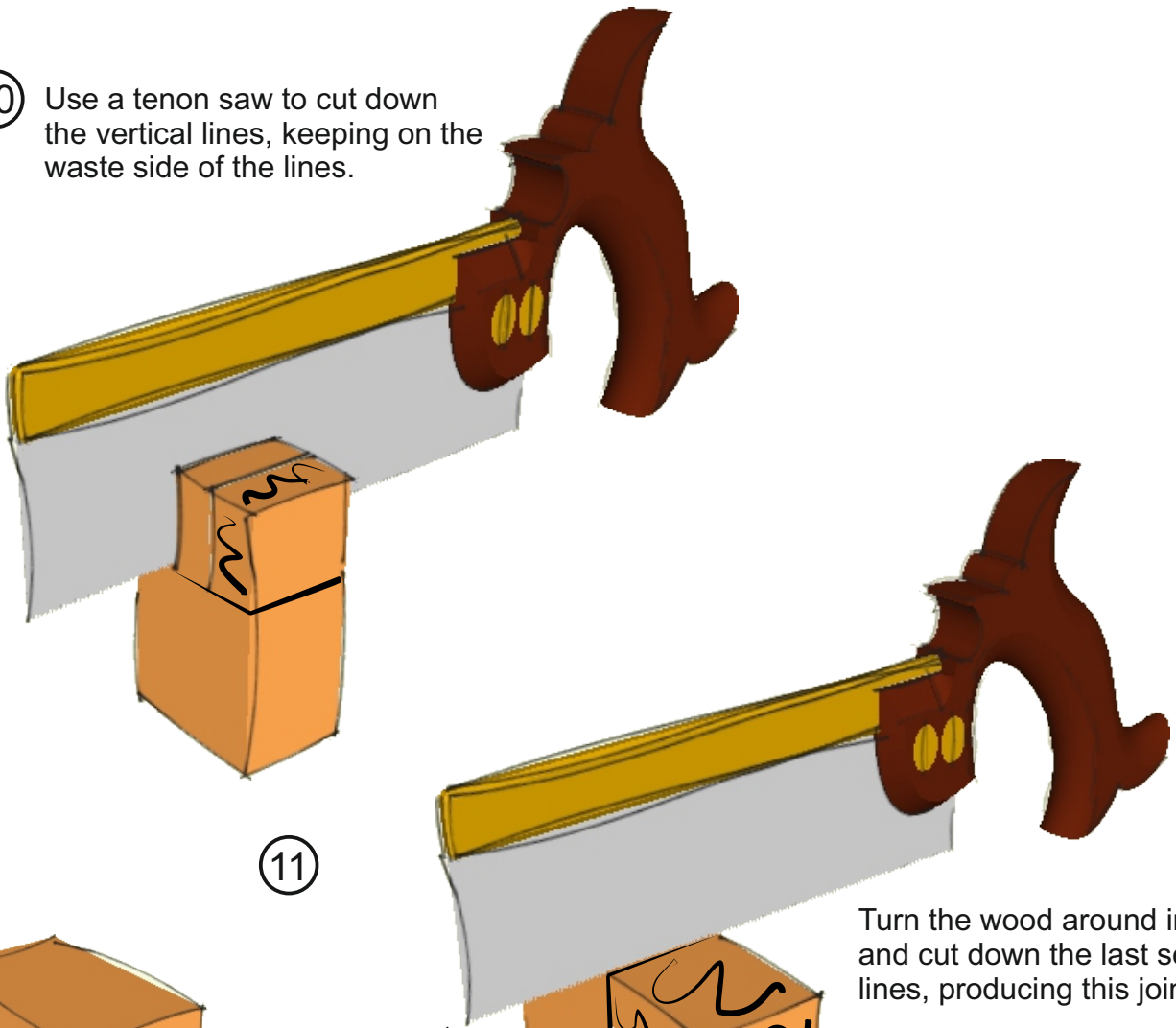

11

Turn the wood around in the vice and cut down the last set of lines, producing this joint.

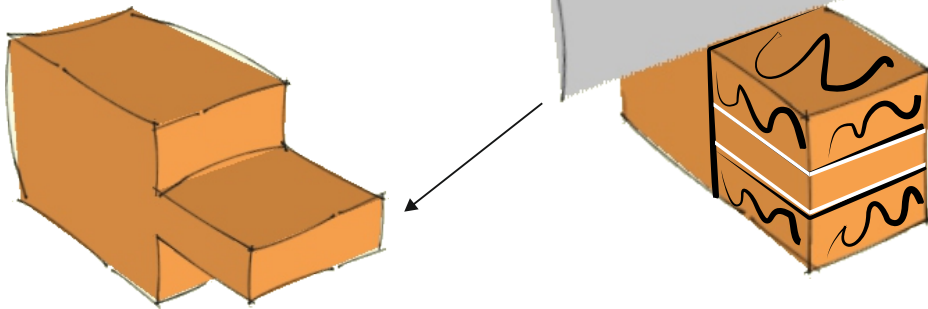

- 12 Fit the joint, as shown in the diagram.

