

1

DESCRIBE THE PROCESS

2

SCALE OF MANUFACTURE SUITED TO THIS PROCESS (✓) (More than one tick may be required)

- ONE OFF / SINGLE ITEM
- BATCH PRODUCTION
- CONTINUOUS PRODUCTION
- JUST IN TIME (JIT)
- COMPUTER INTEGRATED MANUFACTURE
- REMOTE MANUFACTURING
- FLEXIBLE MANUFACTURING
- LEAN MANUFACTURING

3

SKETCH THE INDUSTRIAL PROCESS SHOWN ABOVE (Sketch the left-hand diagram only)

GALVANISING STEEL AND IRON

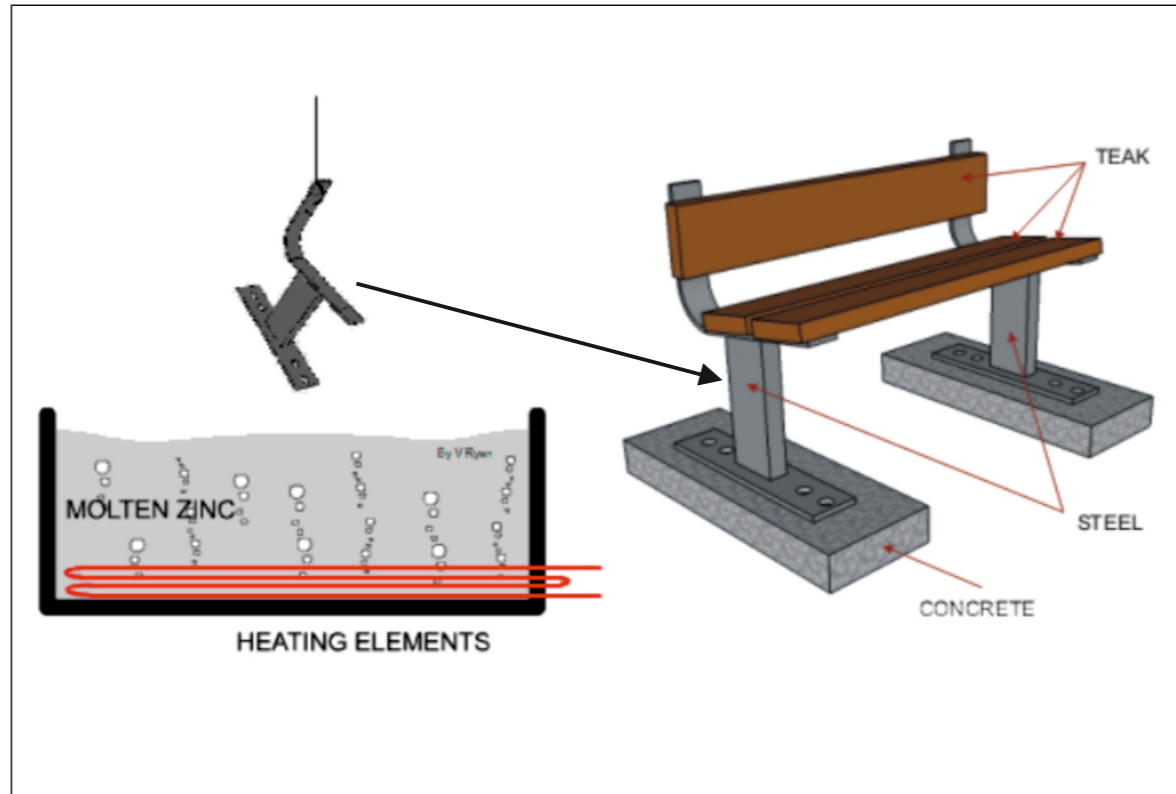

5

PASTE ONE IMAGE OF A GALVANISED PRODUCT

4

LIST PRODUCTS / COMPONENTS THAT ARE GALVANISED

ESSENTIAL LINKS:

- http://www.technologystudent.com/equip_fish/galv1.html
- http://www.technologystudent.com/equip_fish/galv2.html