

THE BENCH DRILL / TABLE TOP PRESS DRILL

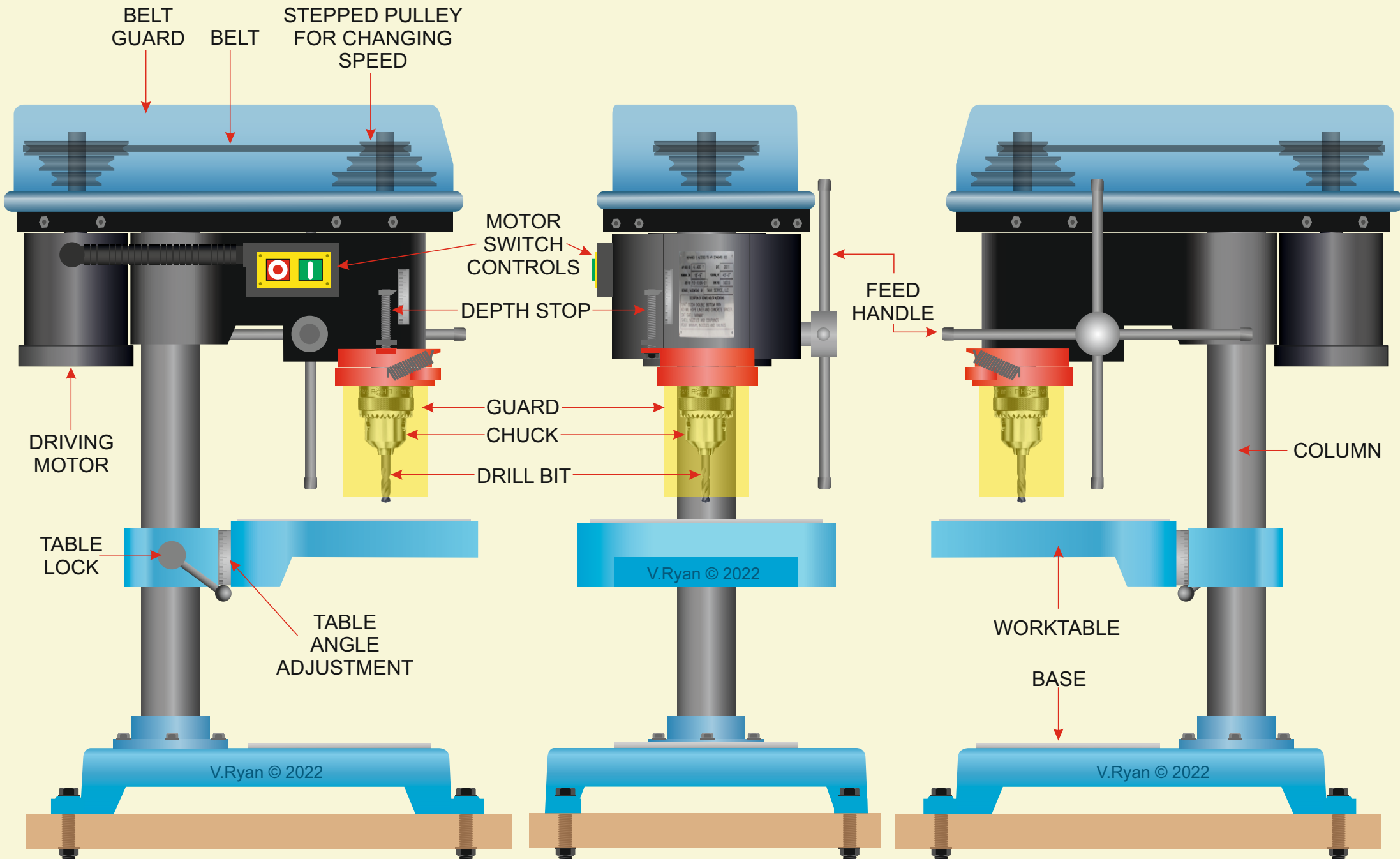

THE BENCH DRILL / TABLE TOP PRESS DRILL

WORLD ASSOCIATION OF TECHNOLOGY TEACHERS

<https://www.facebook.com/groups/254963448192823/>

www.technologystudent.com © 2022 V.Ryan © 2022

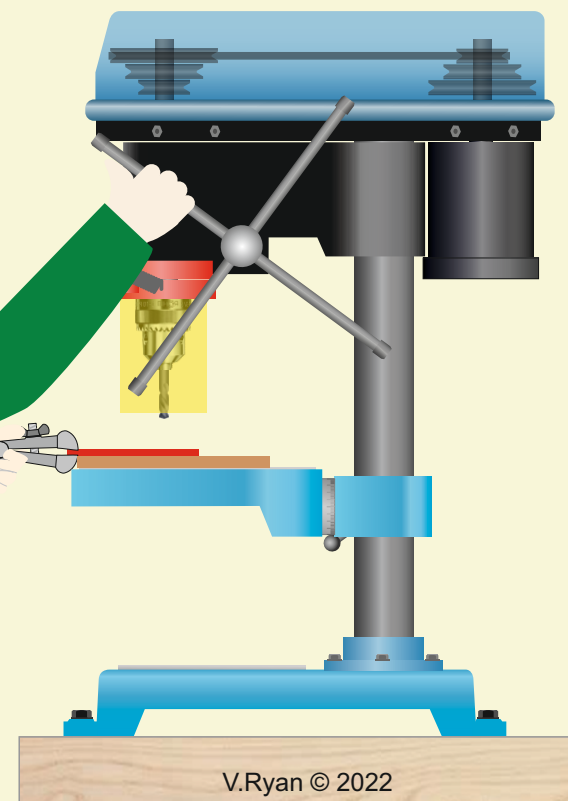
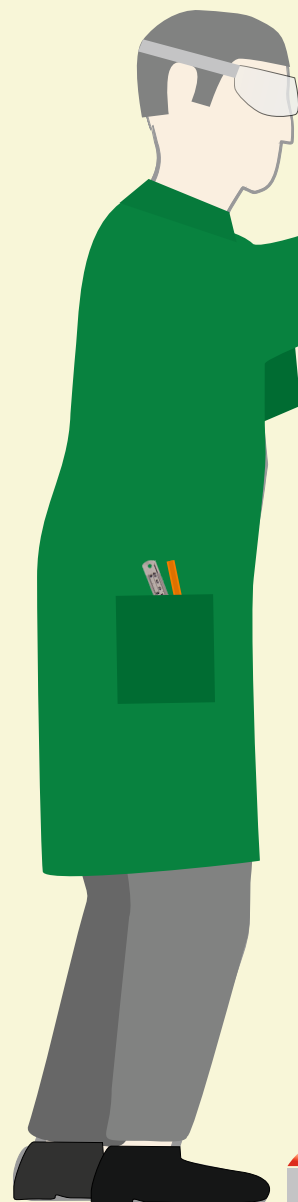
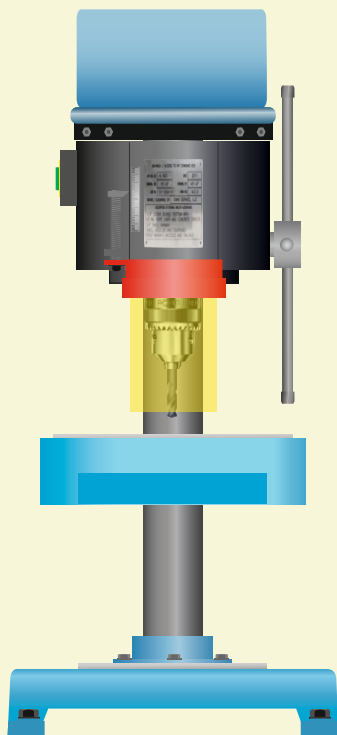

V.Ryan © 2022

DRILLING MACHINE
EQUIPMENT AND
ACCESSORIES



V.Ryan © 2022

WORLD ASSOCIATION OF TECHNOLOGY TEACHERS

<https://www.facebook.com/groups/254963448192823/>

www.technologystudent.com © 2022 V.Ryan © 2022

THE BENCH DRILL / TABLE TOP PRESS DRILL - WITH RACK AND PINION TABLE ADJUSTMENT

The rack and pinion table adjustment, allows the user to lower or higher the machine table with ease. Simply rotate the handle to move the machine table up or down. The machine table is then locked in position.

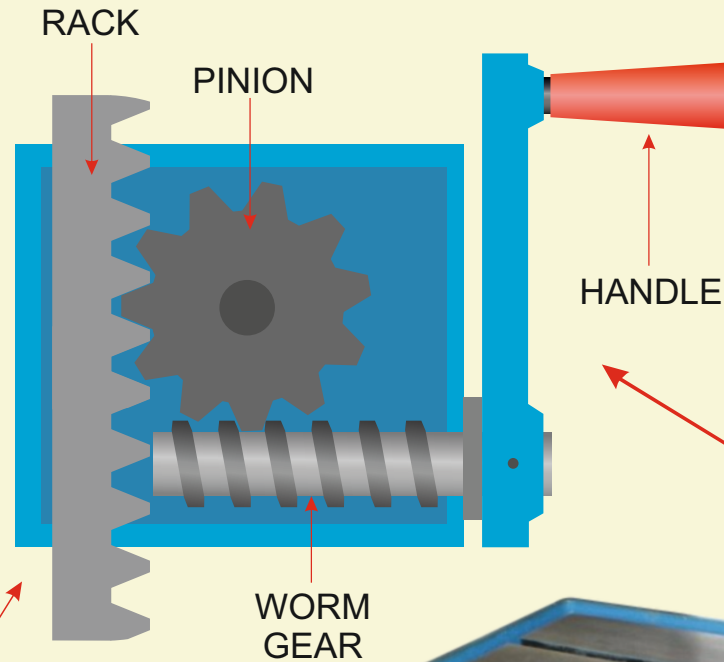
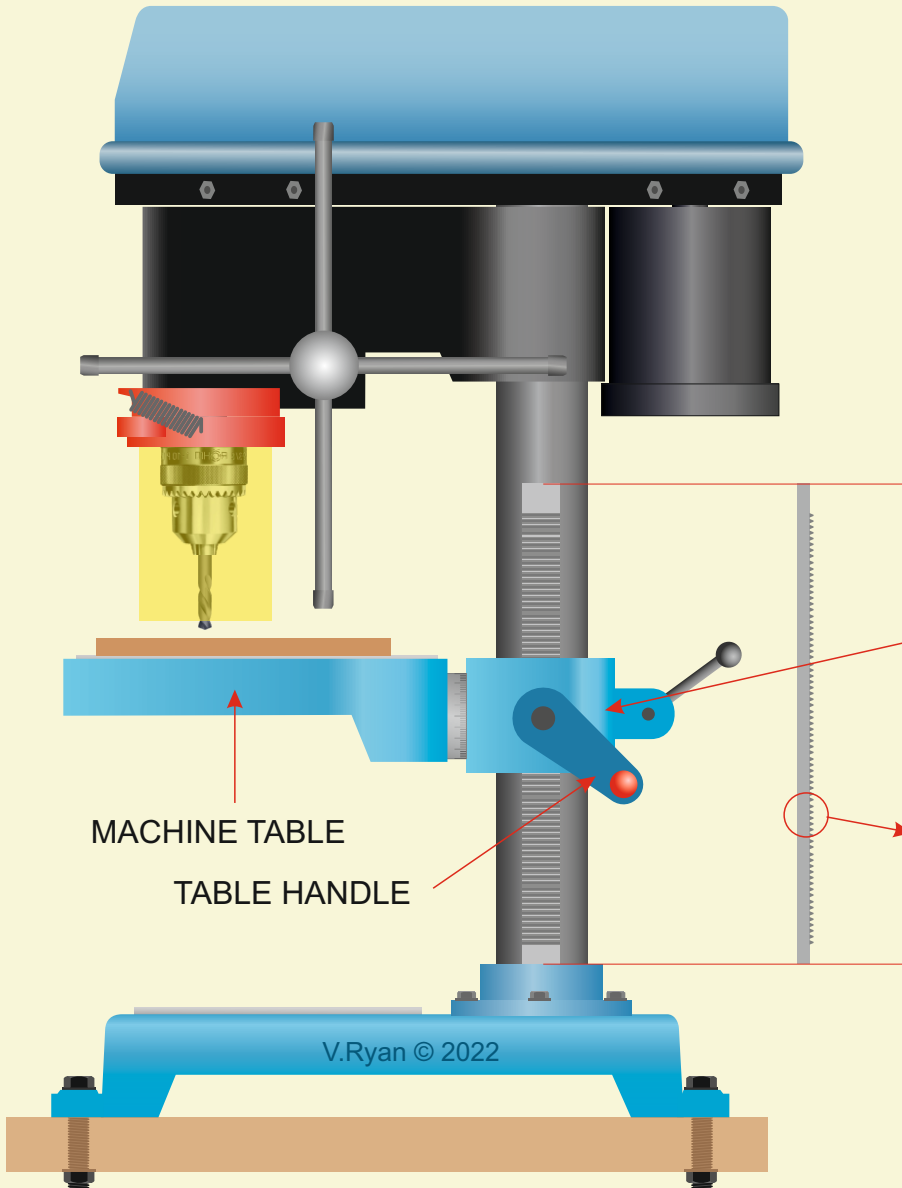

Rotating the handle, rotates the worm gear. The worm gear meshes with the pinion gear, which rotates. The pinion gear meshes with the rack, moving the machine table either up or down.

