

# MODEL ENGINEER CENTRE LATHE

(Based on the Axminster Model Engineer Series SC2 Mini Lathe)

VARIABLE SPEED CONTROL UNIT



THREE JAW CHUCK



TOOL POST, CROSS SLIDE, TOP SLIDE



TAIL STOCK



FEED SELECTOR



(Found at the back of the Headstock)

FOUR SETS OF NUTS AND BOLTS ARE USED TO SECURE THE LATHE TO A SUITABLE TABLE / BENCH

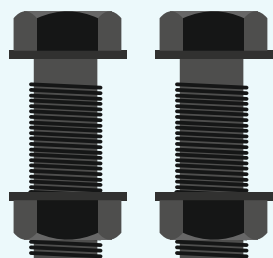

**AXMINSTER SC2**  
V.Ryan © 2022

		mm			
		A	B	C	D
Change Gear Box	0.4	20	50	40	60
	0.5	20	50		60
	0.6	40	50	30	60
	0.7	40	50	35	60
	0.8	40	50	40	60
	1.0	20	60		30
	1.25	50	40		60
	1.5	40	60		40
	1.75	35	60		30
	2.0	40	60		30

GUARD

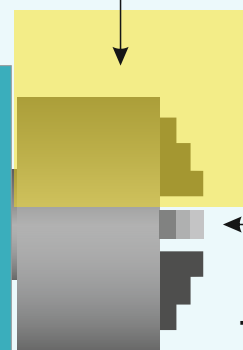

LATHE TOOL

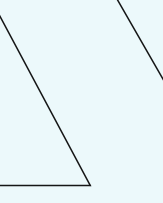

DEAD CENTRE



TAIL STOCK LEVER LOCK

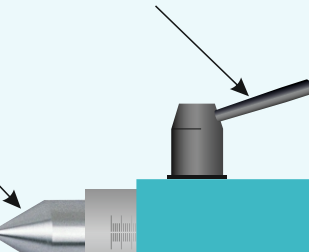

TAIL STOCK SPANNER



METRIC DIAL

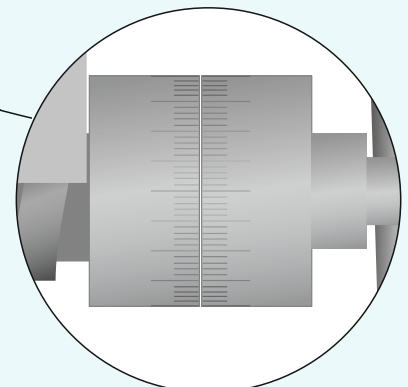

HEAD STOCK

LEAD SCREW

GEAR RACK

SADDLE HANDLE

SADDLE

LEAD SCREW ENGAGE LEVER

TOP SLIDE

CROSS SLIDE