

DRAWING STYLES STARTER

V.Ryan © 2000 - 2013

On behalf of The World Association of Technology Teachers

W.A.T.T.

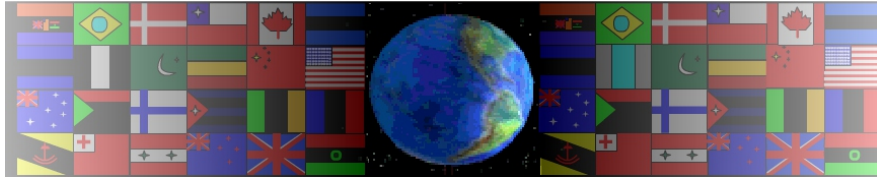

World Association of Technology Teachers

This exercise can be printed and used by teachers and students. It is recommended that you view the website (www.technologystudent.com) before attempting the design sheet .

THESE MATERIALS CAN BE PRINTED AND USED BY TEACHERS AND STUDENTS.
THEY MUST NOT BE EDITED IN ANY WAY OR PLACED ON ANY OTHER MEDIA INCLUDING WEB SITES AND INTRANETS.
NOT FOR COMMERCIAL USE.
THIS WORK IS PROTECTED BY COPYRIGHT LAW.
IT IS ILLEGAL TO DISPLAY THIS WORK ON ANY WEBSITE/MEDIA STORAGE OTHER THAN www.technologystudent.com

DRAWING STYLES STARTER

V.Ryan © 2013 World Association of Technology Teachers

Designers use a variety of drawing styles to communicate their work, to clients and customers. Below is a simple camera. Sketch the camera in estimated two point perspective (use the guidelines).

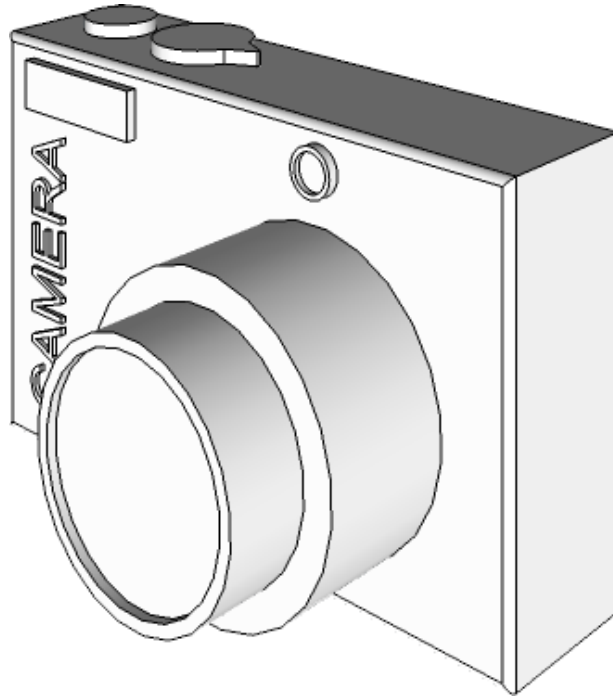

TWO POINT PERSPECTIVE

