

ESTIMATED TWO POINT PERSPECTIVE DRAWING SEED BOX / CONTAINER

V.Ryan © 2000 - 2016

On behalf of The World Association of Technology Teachers

W.A.T.T.



World Association of Technology Teachers

This exercise can be printed and used by teachers and students. It is recommended that you view the website (www.technologystudent.com) before attempting the design sheet .

THESE MATERIALS CAN BE PRINTED AND USED BY TEACHERS AND STUDENTS.
THEY MUST NOT BE EDITED IN ANY WAY OR PLACED ON ANY OTHER MEDIA INCLUDING WEB SITES AND INTRANETS.
NOT FOR COMMERCIAL USE.
THIS WORK IS PROTECTED BY COPYRIGHT LAW.
IT IS ILLEGAL TO DISPLAY THIS WORK ON ANY WEBSITE/MEDIA STORAGE OTHER THAN www.technologystudent.com

ESTIMATED TWO POINT PERSPECTIVE DRAWING

V.Ryan © 2016 World Association of Technology Teachers

A completed perspective drawing of the seed box is seen opposite. This is an example of 'estimated perspective', because the vanishing points are 'off' the page.

Complete the perspective at the bottom of the page.
Add suitable colour, shade.

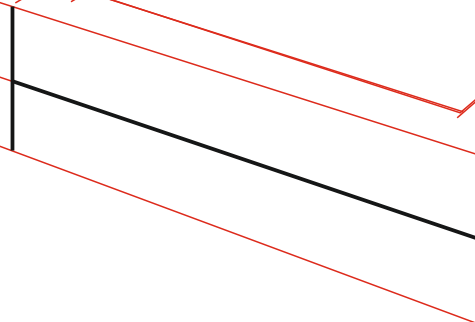
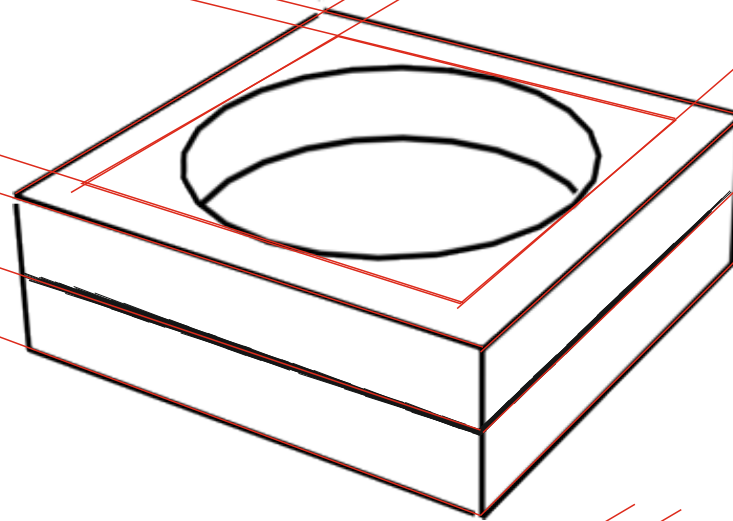

ESTIMATED TWO POINT PERSPECTIVE DRAWING

V.Ryan © 2016 World Association of Technology Teachers

Complete the perspective drawing of the seed box and 'Fruity Snack' container in the space below. This is an example of 'estimated perspective', because the vanishing points are 'off' the page. Add an indication of colour, shade.

