

MARKING OUT AND CUTTING - A SIMPLE SHOULDER / REBATE / LAP JOINT

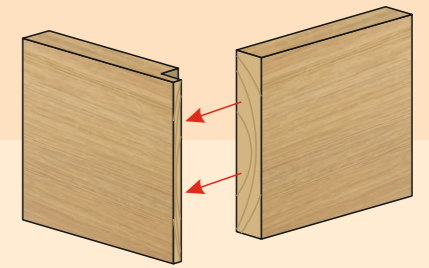

Dia. A

MARK THE 'FACE SIDE' AND 'FACE EDGE' ON BOTH PIECES OF WOOD. THESE ARE THE EDGES YOU WILL WORK FROM, WHEN MARKING OUT THE JOINT. MARK '1' ON EACH PIECE, AS SHOWN BELOW.

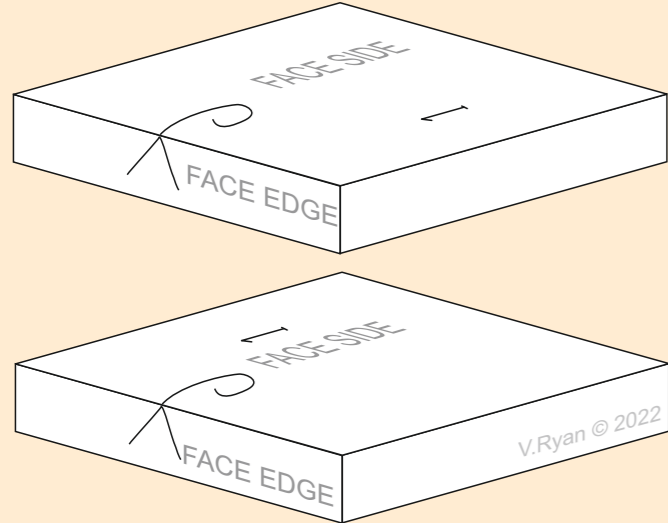

Dia. B

ALIGN THE TWO PIECES. ENSURE THAT THE NUMBERS ARE NEXT TO EACH OTHER AND THE 'FACE EDGES' LINE UP.

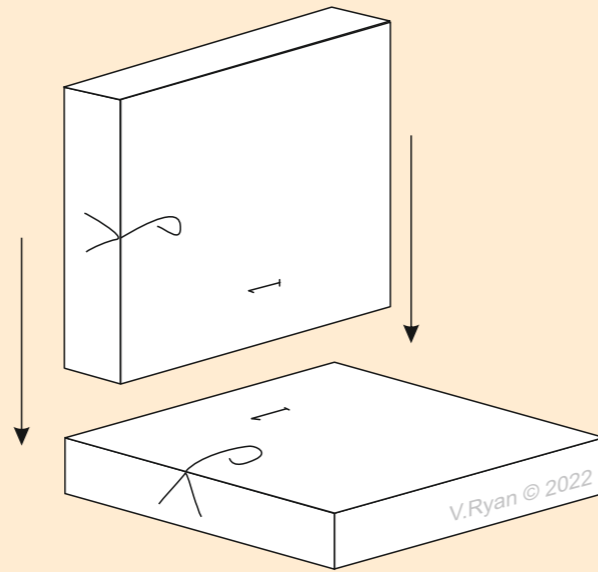

USE A MARKING KNIFE TO 'MARK' THE THICKNESS OF THE TOP ON THE BOTTOM PIECE.

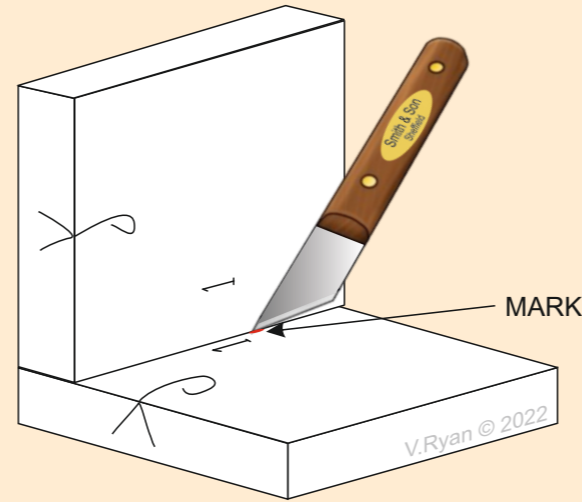

Dia. C

ON THE BOTTOM PIECE ONLY - USE A TRY SQUARE AND MARKING KNIFE TO MARK A LINE ACROSS THE FACE SIDE AND DOWN THE TWO EDGES. PLACE THE STOCK OF THE TRY SQUARE AGAINST THE 'FACE EDGE'.

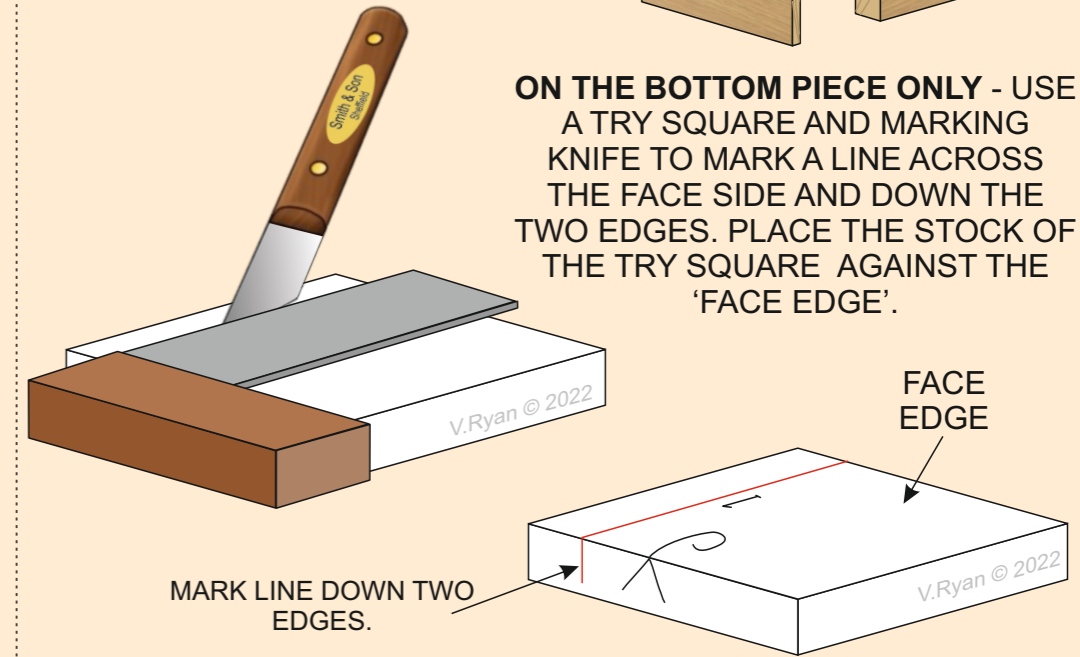

Dia. D

USE A MARKING GAUGE, TO MARK THE LINES, ALONG THE 'END' AND DOWN EACH EDGE, CLEARLY SHOWING THE WASTE WOOD.

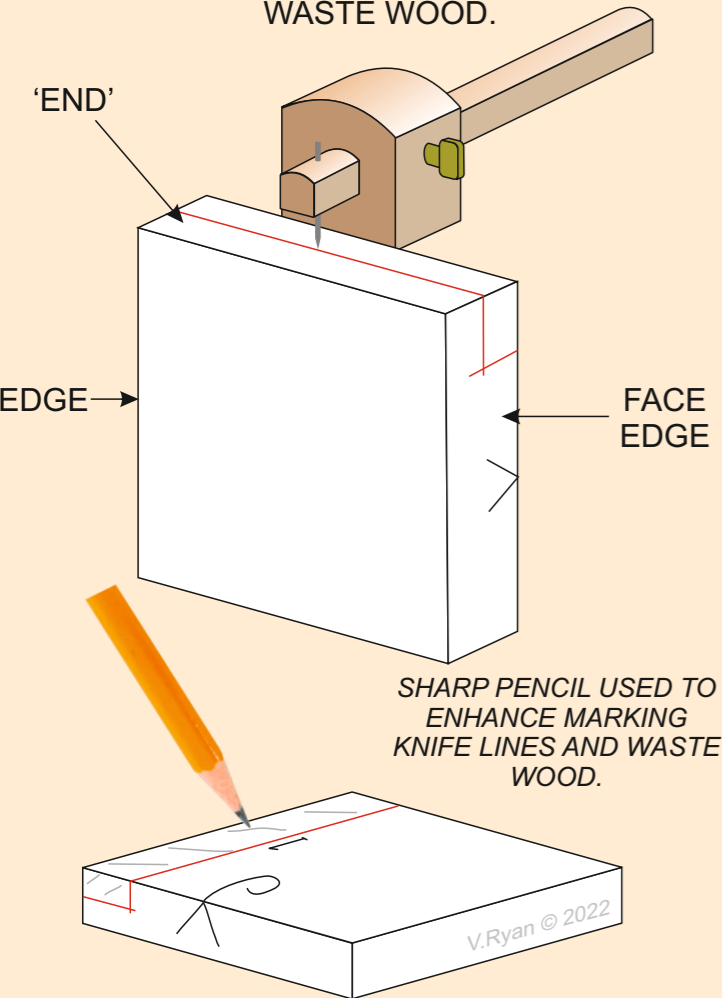

Dia. E

SECURE THE WOOD IN A VICE. SAW DOWN, CUTTING ON THE WASTE WOOD SIDE OF THE LINES.

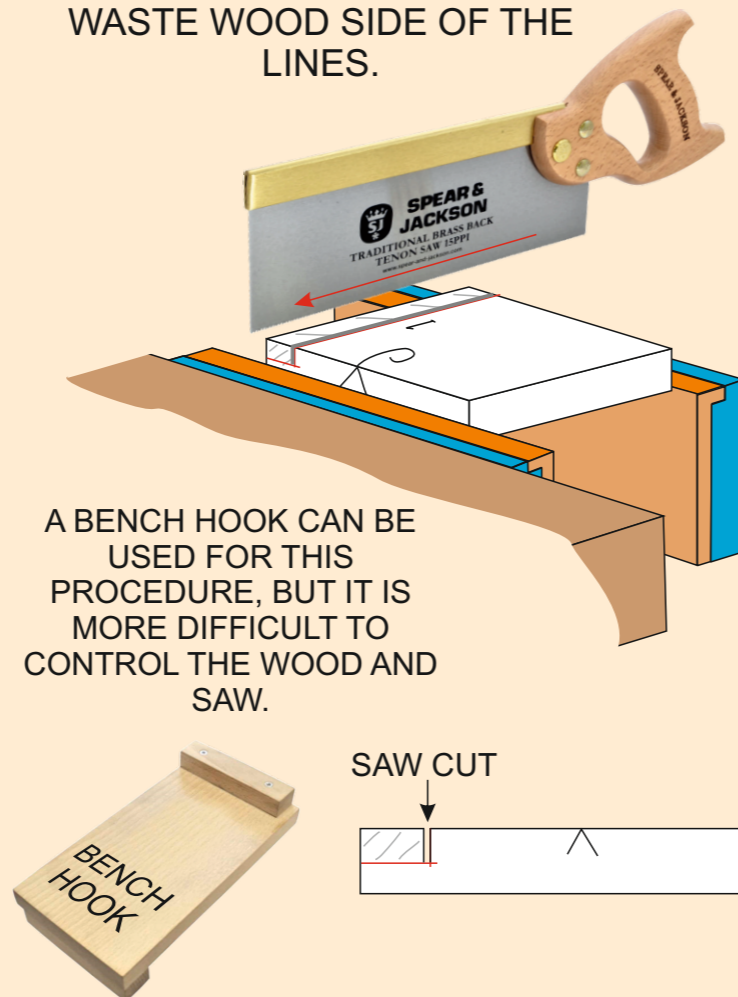

Dia. F

TURN THE WOOD ROUND IN THE VICE AND SECURE AS SHOWN HERE. CUT DOWN WITH A SAW AND REMOVE WASTE WOOD.

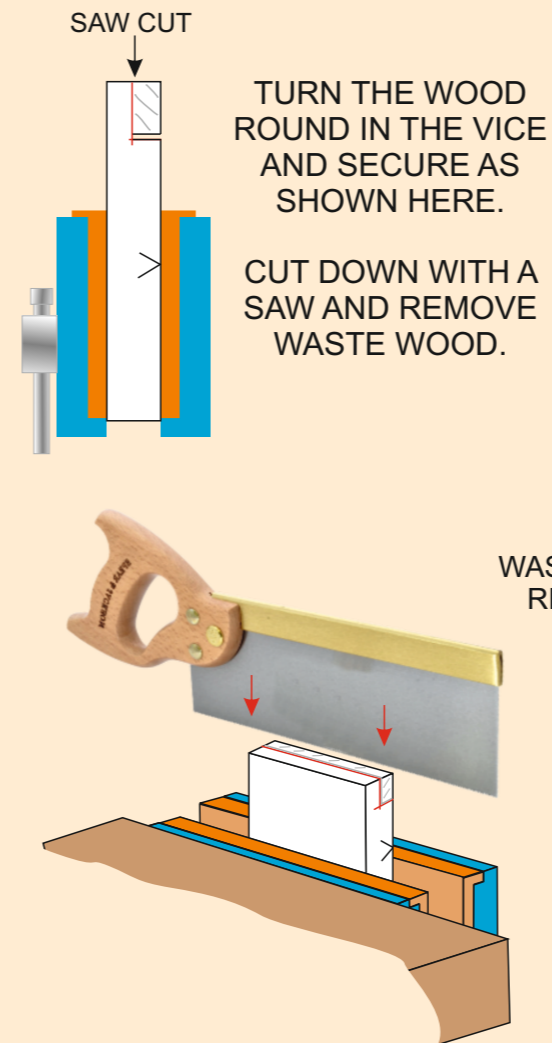

Dia. G

MAKE THE FINAL 'CUT' WITH A CHISEL. THE CHISEL'S SHARP EDGE, SHOULD BE LODGED IN THE LINE PRODUCED BY THE MARKING KNIFE / GAUGE. TAP THE CHISEL TO REMOVE THE FINAL WASTE WOOD.

