

MARKING OUT AND CUTTING - MITRE, CORNER HALVING JOINT

FIRST PIECE

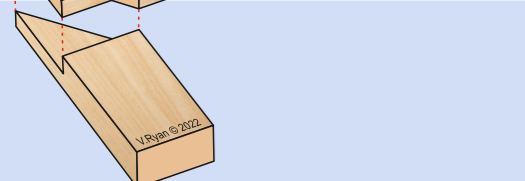

Dia. A

MARK THE WIDTH OF THE JOINT, AS SHOWN BELOW.

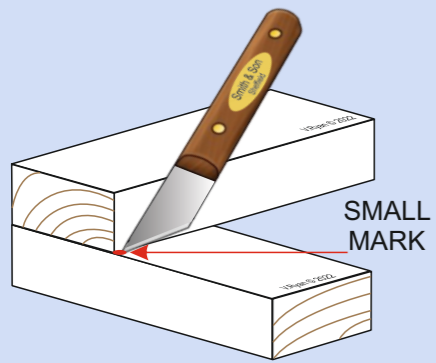

SMALL MARK

Dia. B MARK OUT THE JOINT USING A MITRE SQUARE, CREATING A 45° LINE.

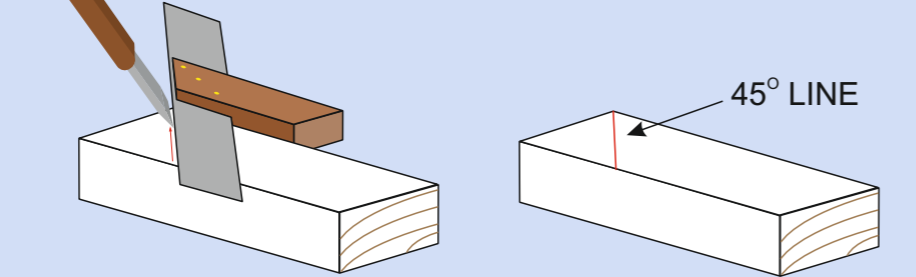

45° LINE

USE A TRY SQUARE TO MARK A LINE, HALF WAY DOWN THE SIDE.

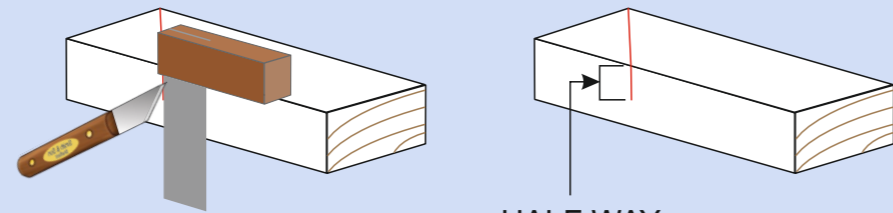

HALF WAY DOWN SIDE

Dia. C

SET A MARKING GAUGE TO HALF THE WIDTH OF THE WOOD

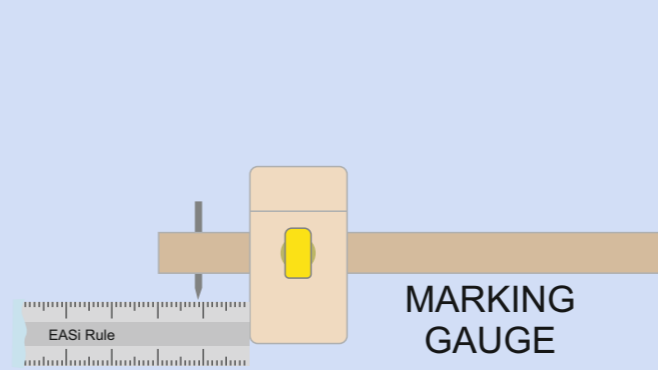

MARKING GAUGE

Dia. D

USE A MARKING GAUGE TO COMPLETE THE MARKING OUT - THE TOP AND SIDE.

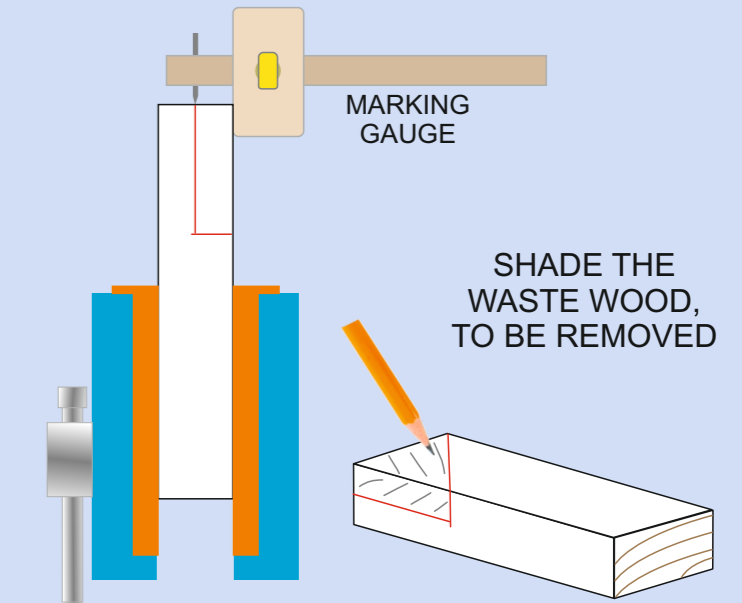

MARKING GAUGE

SHADE THE WASTE WOOD, TO BE REMOVED

Dia. E

SECURE THE WOOD IN A VICE. SAW DOWN THE 'DIAGONAL' LINE, CUTTING ON THE WASTE WOOD SIDE OF THE LINES.

NOTE: A MANUAL MITRE SAW IS PERFECT FOR THIS PROCEDURE (SEE ON PAGE TWO)



DIAGONAL MARKING OUT LINE

SAW CUT ON DIAGONAL LINE

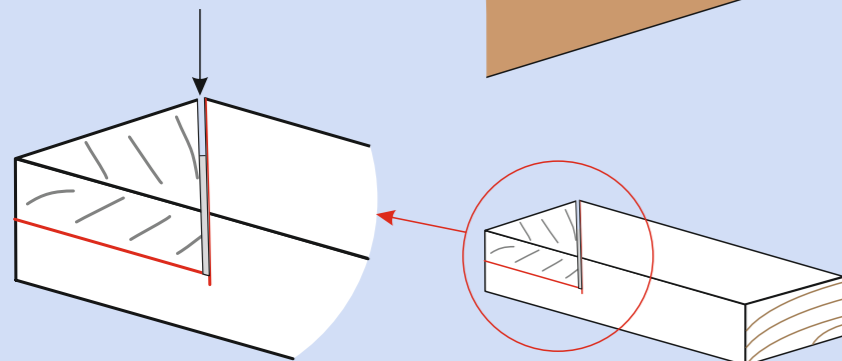

Dia. F

TURN THE WOOD AROUND IN THE VICE. MAKE THE FINAL SAW CUT DOWNWARDS, REMOVING THE WASTE WOOD.

NOTICE HOW THE WOOD IS POSITIONED IN THE VICE

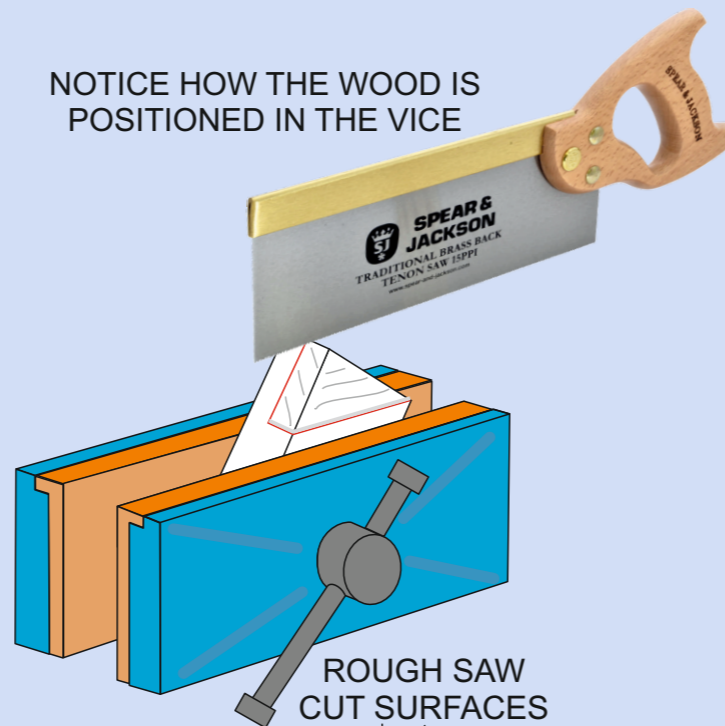

ROUGH SAW CUT SURFACES

Dia. G

MAKE THE FINAL 'CUT' WITH A CHISEL. THE CHISEL'S SHARP EDGE, SHOULD BE LODGED IN THE LINE PRODUCED BY THE MARKING KNIFE. TAP THE CHISEL TO REMOVE THE FINAL WASTE WOOD.

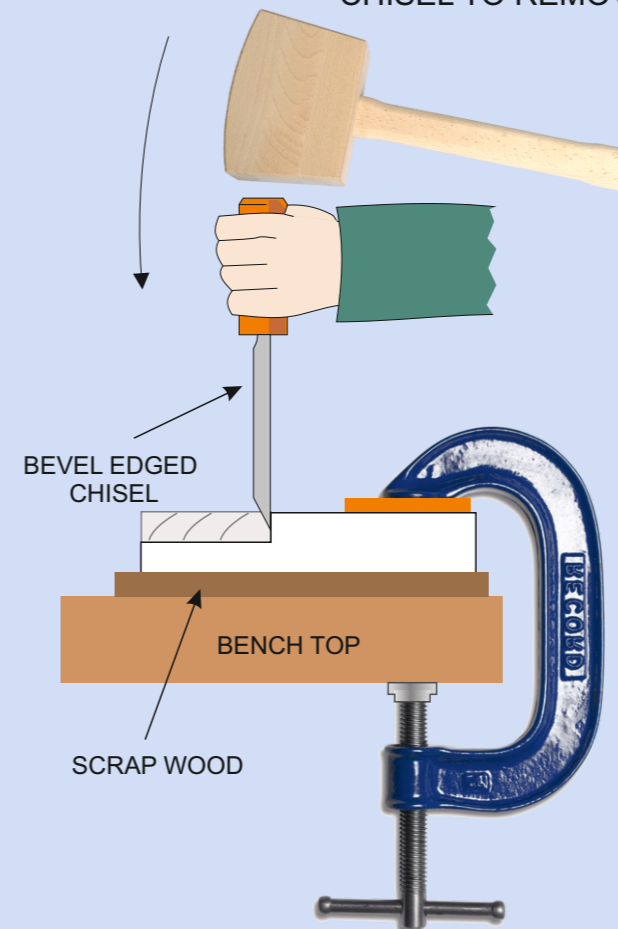

BEVEL EDGED CHISEL

BENCH TOP

SCRAP WOOD

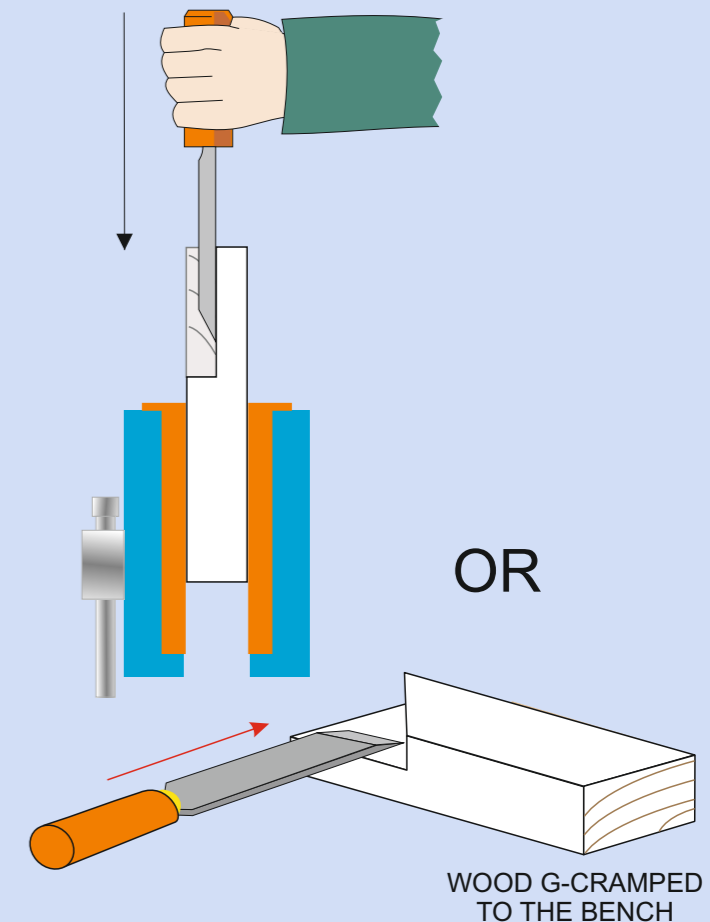

OR

WOOD G-CRAMPED TO THE BENCH

MARKING OUT AND CUTTING - MITRE, CORNER HALVING JOINT

SECOND PIECE

WORLD ASSOCIATION OF TECHNOLOGY TEACHERS <https://www.facebook.com/groups/254963448192823/> www.technologystudent.com © 2022 V.Ryan © 2022

Dia. H

MARK OUT THE JOINT USING A MITRE SQUARE, CREATING A 45° LINE.

45° LINE

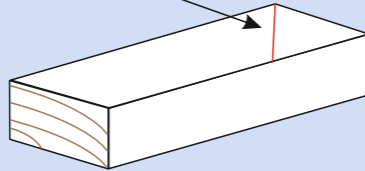

USE A TRY SQUARE TO MARK A LINE ALL THE WAY DOWN THE SIDE.

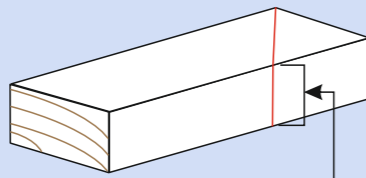
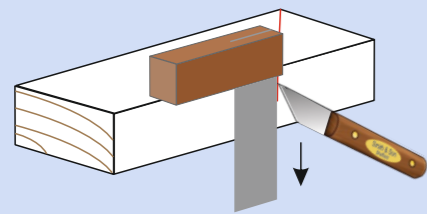

ALL WAY DOWN SIDE

Dia. I

MARK THE WASTE WOOD WITH A PENCIL AND REMOVE IT WITH A SAW.

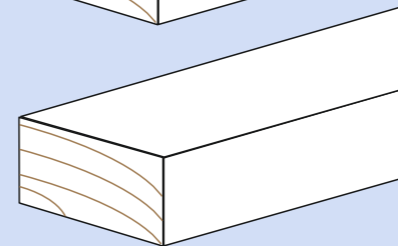
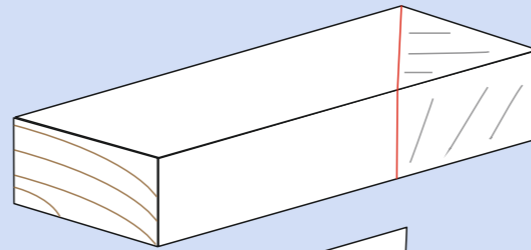

A HAND MITRE SAW IS PERFECT FOR CUTTING ANGLES.

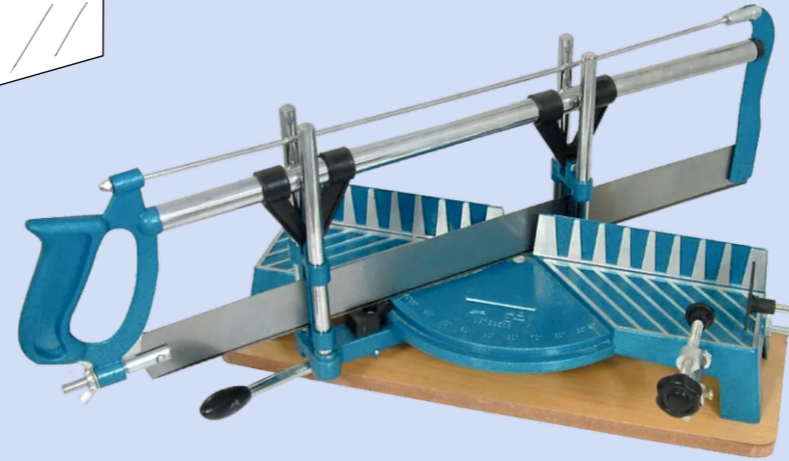

Dia. J

USE A MARKING GAUGE TO MARK HALF THE THICKNESS OF THE WOOD

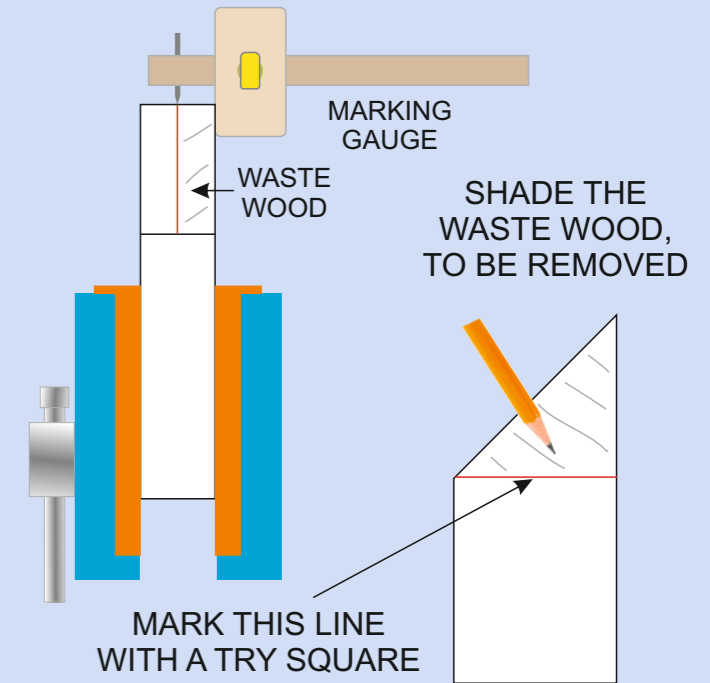

WORLD ASSOCIATION OF TECHNOLOGY TEACHERS <https://www.facebook.com/groups/254963448192823/> www.technologystudent.com © 2022 V.Ryan © 2022

Dia. K

SECURE THE WOOD IN A VICE. SAW ACROSS THE LINE, CUTTING ON THE WASTE WOOD SIDE.



MARKING OUT LINE

A BENCH HOOK CAN BE USED FOR THIS PROCEDURE, BUT IT IS MORE DIFFICULT TO CONTROL THE WOOD AND SAW.



SAW GROOVE

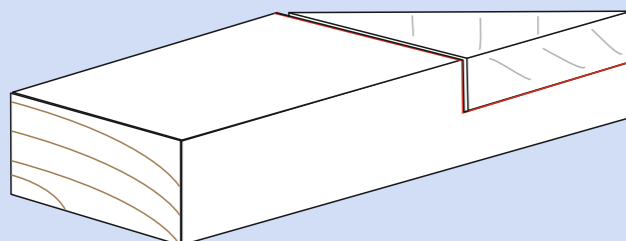

Dia. L

TURN THE WOOD AROUND IN THE VICE. MAKE THE FINAL SAW CUT DOWNWARDS, REMOVING THE WASTE WOOD.

NOTICE HOW THE WOOD IS POSITIONED IN THE VICE

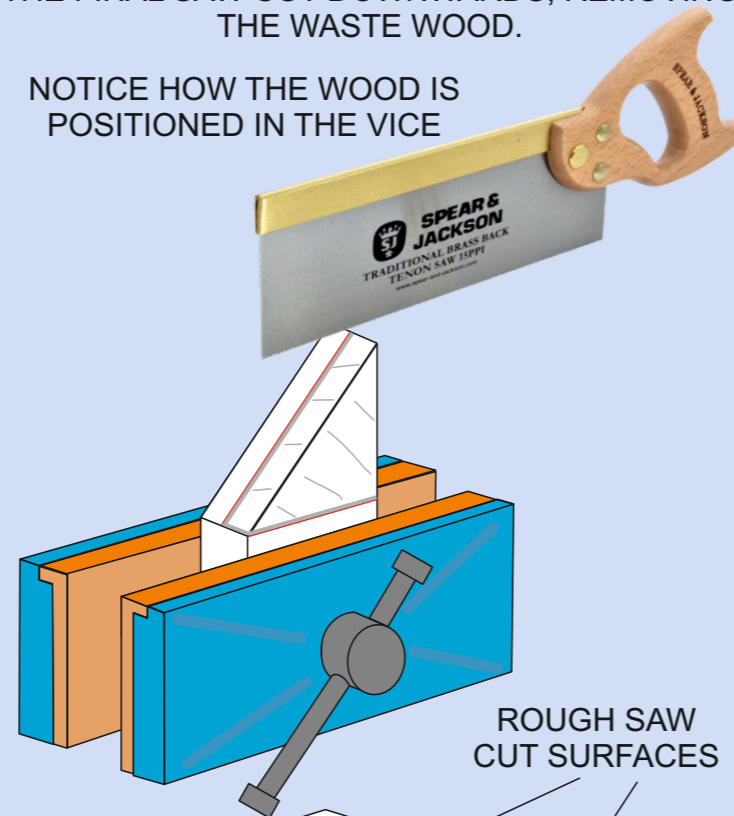

ROUGH SAW CUT SURFACES

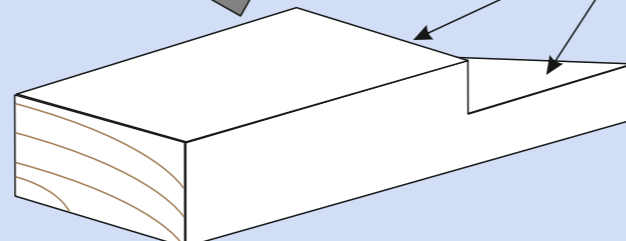

Dia. M

MAKE THE FINAL 'CUT' WITH A CHISEL. THE CHISEL'S SHARP EDGE, SHOULD BE LODGED IN THE LINE PRODUCED BY THE MARKING KNIFE. TAP THE CHISEL TO REMOVE THE FINAL WASTE WOOD.

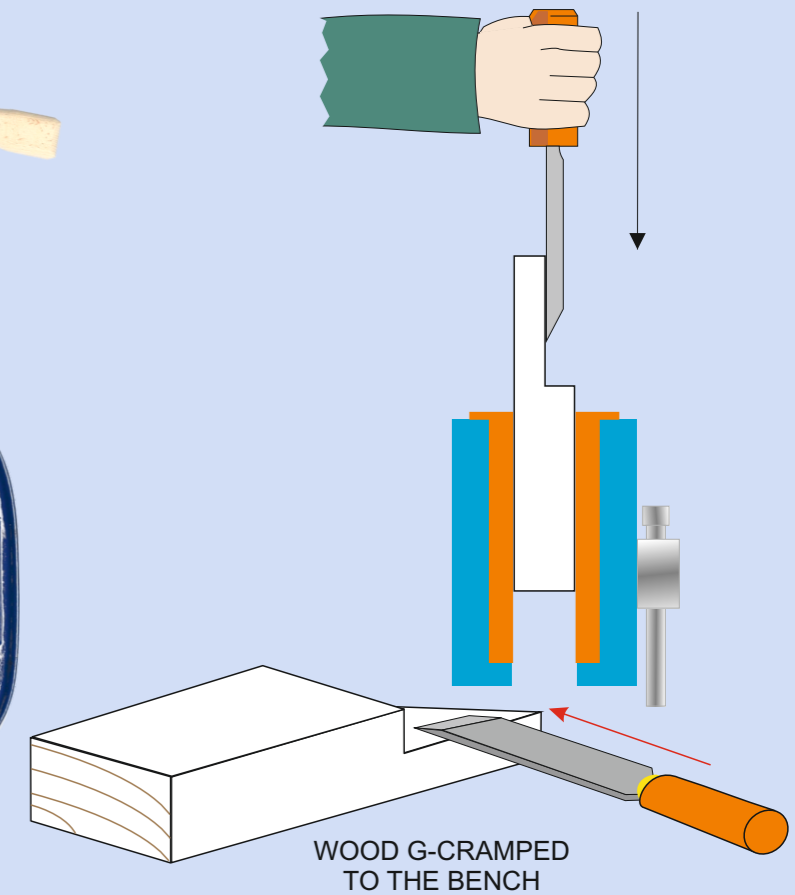
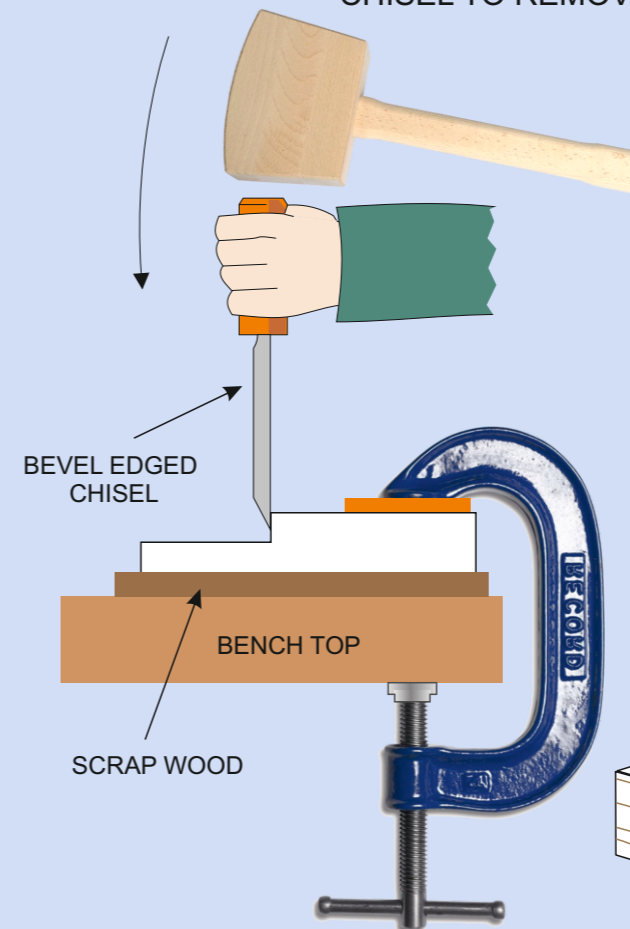

WOOD G-CRAMPED TO THE BENCH

NOW FIT THE JOINT TOGETHER

WORLD ASSOCIATION OF TECHNOLOGY TEACHERS <https://www.facebook.com/groups/254963448192823/> www.technologystudent.com © 2022 V.Ryan © 2022