

FINGER JOINTS

V.Ryan © 2000 - 2008

On behalf of The World Association of Technology Teachers

W.A.T.T.

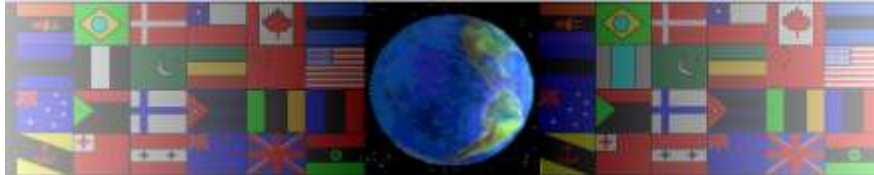

World Association of Technology Teachers

The 'Finger/Comb Joint Exercise' can be printed and used by teachers and students. It is recommended that you view the website (www.technologystudent.com) before attempting the design sheet.

THESE MATERIALS CAN BE PRINTED AND USED BY TEACHERS AND STUDENTS.
THEY MUST NOT BE EDITED IN ANY WAY OR PLACED ON ANY OTHER MEDIA INCLUDING WEB SITES AND INTRANETS.
NOT FOR COMMERCIAL USE.
THIS WORK IS PROTECTED BY COPYRIGHT LAW.
IT IS ILLEGAL TO DISPLAY THIS WORK ON ANY WEBSITE/MEDIA STORAGE OTHER THAN www.technologystudent.com

FINGER JOINTS - PART TWO

The incomplete stages of marking out and cutting a typical finger/comb joint. Complete the stages by adding the missing descriptions and drawings.

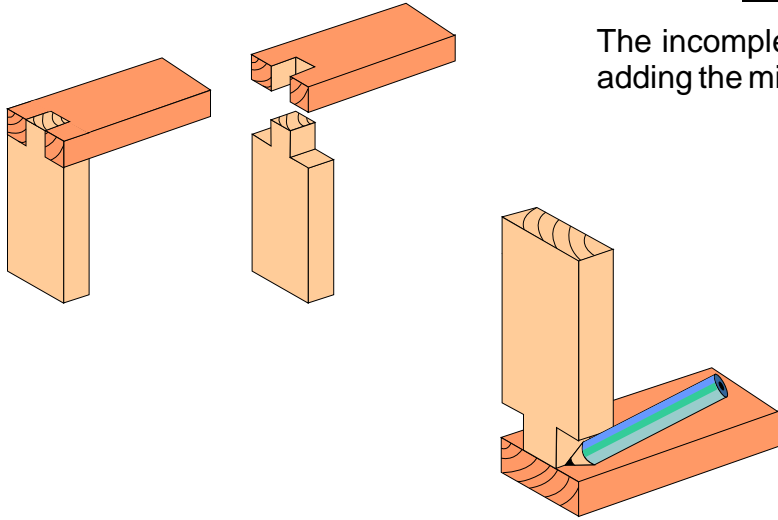

7. THE FIRST SIDE IS PLACED ABOVE THE SECOND SIDE OF THE JOINT AND THE JOINT IS MARKED OUT. AGAIN A PENCIL IS USED ALTHOUGH THE TRADITIONAL TOOL WOULD BE A MARKING KNIFE.

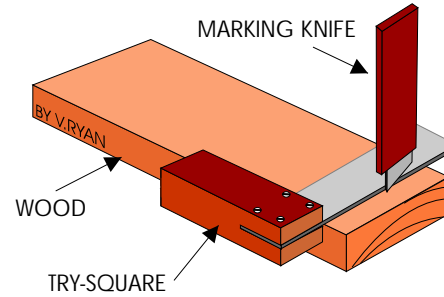

8. _____

9. THE TENON SAW IS USED TO CUT DOWN THE LINES MARKING THE MIDDLE SECTION OF THE JOINT, ON THE WASTE SIDE OF THE PENCILLINE.

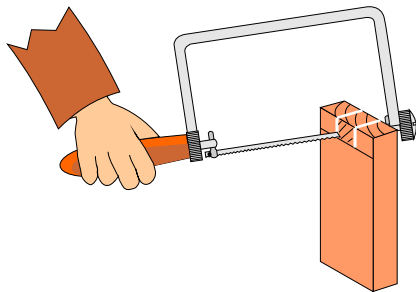

10. _____

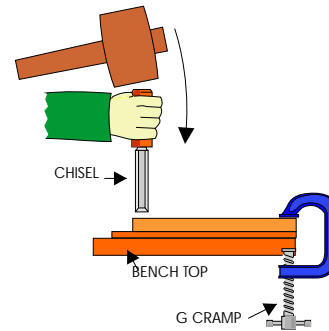

11. _____

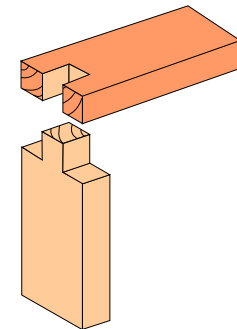

12. _____

