

SAMPLE GRAPHIC PRODUCTS

GCSE EXAMINATION PAPER

CENTRE NUMBER

--	--	--	--	--

CANDIDATE NUMBER

--	--	--	--

SAMPLE PAPER 2

SURNAME _____

FORENAME(S) _____

CANDIDATE SIGNATURE _____

2 HOURS ALLOWED

Materials required for this examination:

- normal writing and drawing instruments
- a calculator
- a protractor.

Instructions to candidates:

- Use black ink or black ball-point pen. Use pencil only for drawing.
- Fill in the boxes at the top of this page.
- Answer **all** questions.
- You must answer the questions in the spaces provided. Do not write on blank pages.
- Do all rough work in this book. Cross through any work that you do not want to be marked.

Information

- The marks for the questions are shown in brackets.
- The maximum mark for this paper is **140**.
- Section A relates to the context given in the Preliminary Material that was previously issued. **35 marks** Section B - **105 marks**
- You are reminded of the need for good English and clear presentation in your answers. Quality of written communication will be assessed in Question 4 (a).

This example examination paper can be duplicated and printed out if required but not edited in any way.

The links to www.technologystudent.com cannot be removed.

The PDF file can be stored on school / college systems and distributed electronically (NO EDITING ALLOWED)

PLEASE RESPECT THE COPYRIGHT - report infringers to techteacher@technologystudent.com
Not be distributed at courses or by course instructors / consultants

SECTION A

This section is concerned with designing

Section A is about designing

You are advised to spend about 35 minutes on this question.

Design Theme: FANTASY PAPER TOY CHARACTERS.

Look at the Design Brief and Design Criteria below.

Design Brief

A manufacturer, providing pop-up booklets for a new breakfast cereal, as a promotion, has asked you to design a Fantasy Paper Toy Character. The character must be three dimensional and 'popup' when a simple story booklet is opened.



Design Criteria

You have been asked to design a pop-up fantasy paper toy character, which will be a the min feature of a pop-up booklet, placed inside the packaging of a new breakfast cereal..

The graphics must:

- be based on a 'Party / fun theme', with any text in a suitable letter style (typeface)
- display colourful images of **party / fun** characters, suitable for young children.
- appeal to children.

TO HELP YOU ANSWER THIS
QUESTION, FOLLOW THE LINKS

<http://www.technologystudent.com/despro2/toy4.html>
<http://www.technologystudent.com/despro2/toy5.html>
<http://www.technologystudent.com/despro2/toy6.html>

1a. In the four spaces below, draw four BASIC designs, for a suitable fantasy paper toy character, that could be developed into a folding 3D form. **4 x 2 marks**

Marks awarded for each character.

Basic design 1 mark

More detailed design 2 marks

TO HELP YOU ANSWER THIS
QUESTION, FOLLOW THE LINKS

<http://www.technologystudent.com/despro2/toy8.html>

http://www.technologystudent.com/despro_flsh/graphics_popup1.html

1. The Fantasy Character will be a pop-up design. draw two 'rough' or 'outline' designs for the popup mechanism / movement. Your designs should show how the pop-up will work. Do not add colour, as this question is concerned with producing a basic outline design. **2 x 2marks**

1b. Pop-up design

1 mark for basic mechanism / movement that will work.

2 marks for more detailed mechanism / movement that works

1c. Pop-up design

1 mark for basic mechanism / movement that will work.

2 marks for more detailed mechanism / movement that works

TO HELP YOU ANSWER THIS
QUESTION, FOLLOW THE LINKS

<http://www.technologystudent.com/despro2/toy8.html>

http://www.technologystudent.com/despro_flash/graphics_popup1.html

1d. Select your best outline design for the pop-up mechanism / movement and develop it in the space below, adding notes to explain how it works. **4 marks**

Only award marks if the original outline version has been developed.

1 mark for sketch without notes.

2 marks for basic mechanism / movement could work if developed further. Sketch and notes.

3-4 marks for a mechanism / movement that will work. 4 marks for superior detail / explanation. Sketch and notes.

TO HELP YOU ANSWER THIS
QUESTION, FOLLOW THE LINKS

<http://www.technologystudent.com/despro2/toy4.html>
<http://www.technologystudent.com/despro2/toy5.html>
<http://www.technologystudent.com/despro2/toy6.html>
<http://www.technologystudent.com/despro2/toy8.html>
http://www.technologystudent.com/despro_fish/graphics_popup1.html

1e. Using the design criteria below, produce a series of annotated sketches, to show how **ONE** of your characters (from question 1a.), can be developed into a character, that can be folded to form a 3D shape and combined with the pop-up mechanism / movement.

[11 marks]

Use the next two pages to develop your design.

Design Criteria

The graphics must:

- ensure that the fantasy character represents the theme 'party' / 'fun'
- include a suitable colour scheme that supports the party / fun theme.
- your chosen character must appeal to children.
- show clearly detail of the net(s) / development(s) that are folded to form the final character.

Marks will be awarded for:

- effective application of the design criteria
- creativity, imagination, originality and quality of the development, including an indication of colour
- notes explaining your sketches.

1-3 marks for basic development of character with no reference to the net / development shapes / movement/ mechanism.

4-6 marks for basic development including nets, movement and limited notes

7-9 marks for reasonable level of detail and explanation of the development of both the character, nets and movement

10-11 marks for increased level of detail.

Follow the links for sample answers.

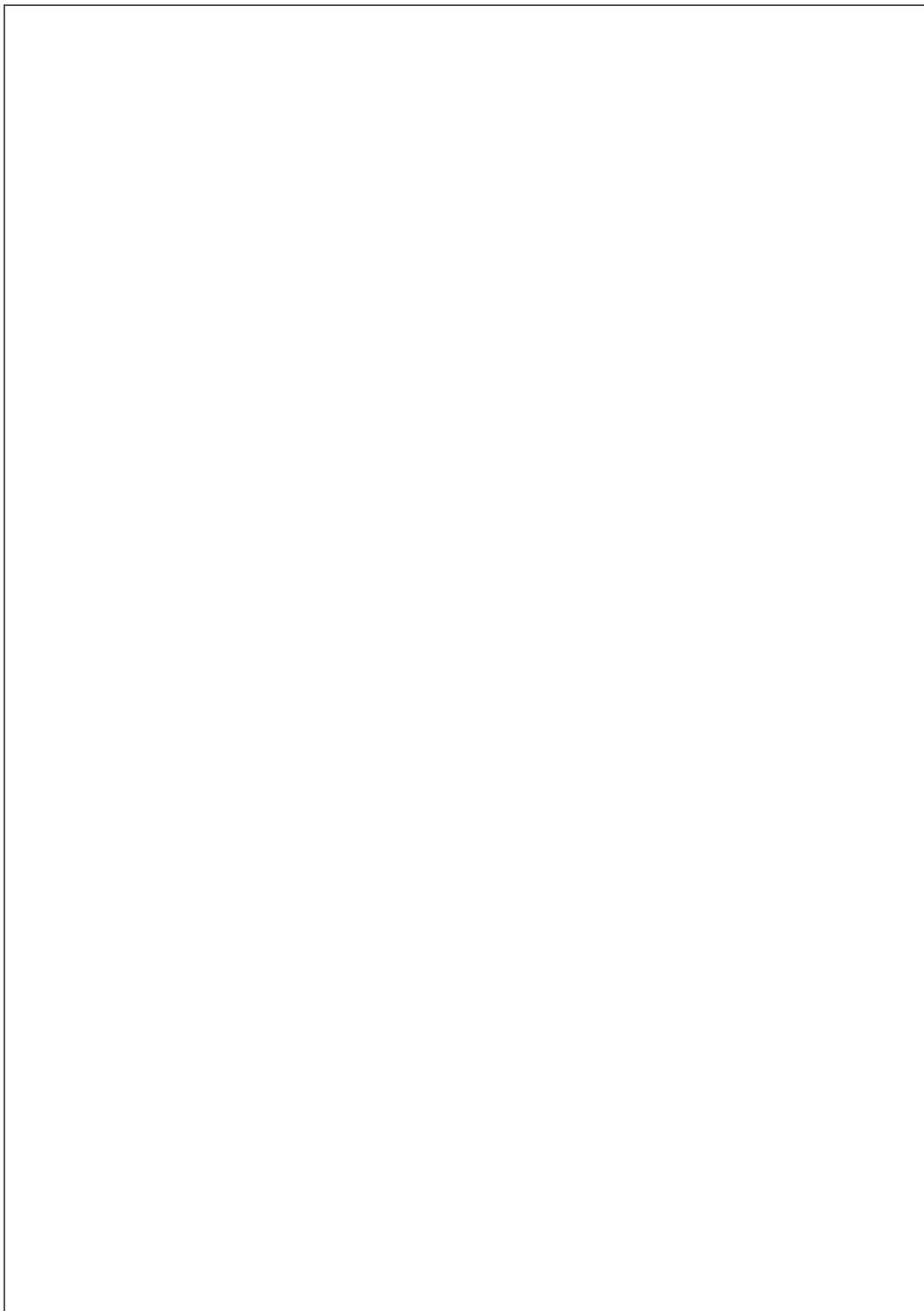

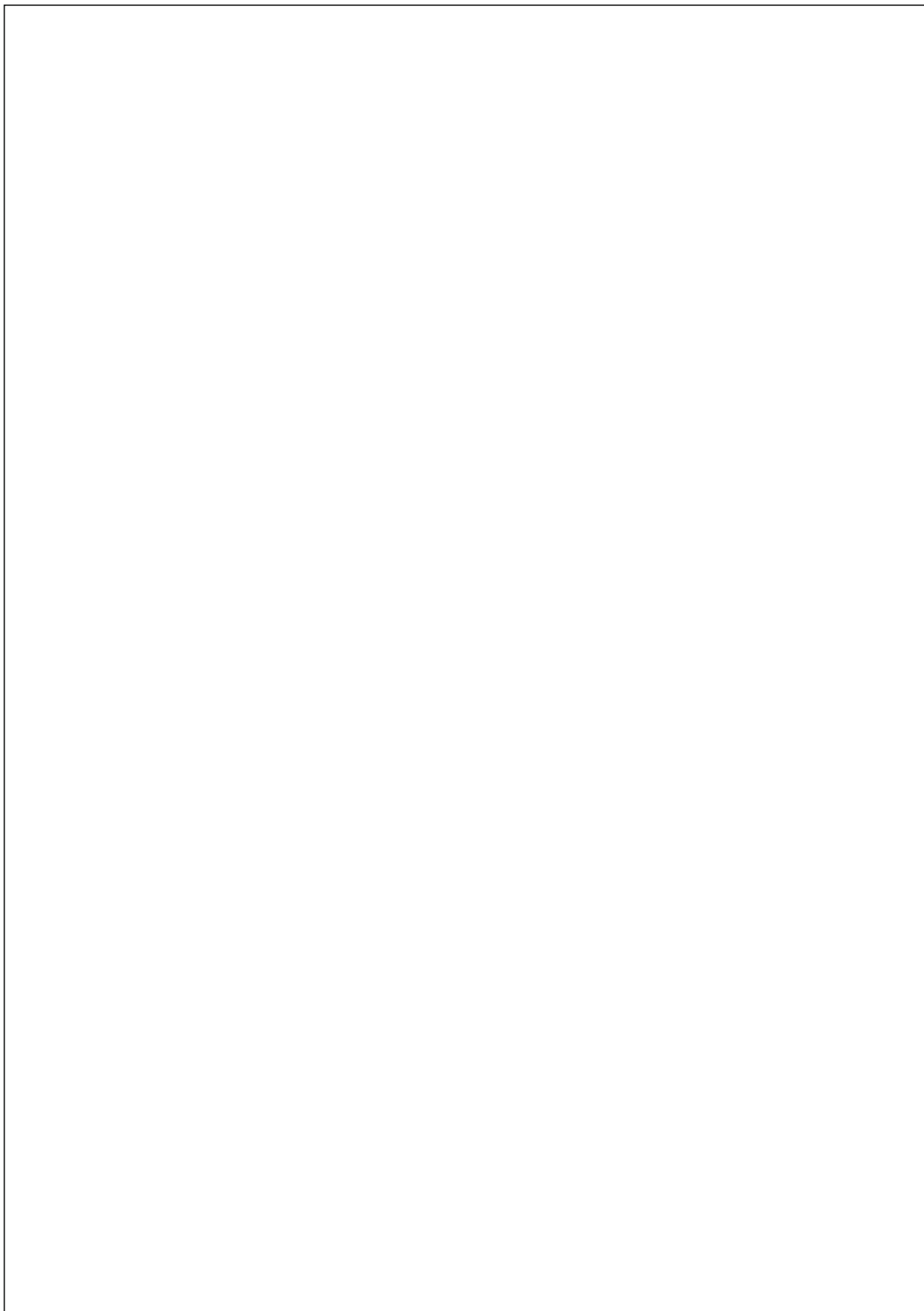

TO HELP YOU ANSWER THIS QUESTION, FOLLOW THE LINKS FOLLOW THE LINKS ON EACH PAGE TO THE PDF FILES

<http://www.technologystudent.com/despro2/toy8.html>
<http://www.technologystudent.com/despro2/toy4.html>
<http://www.technologystudent.com/despro2/toy5.html>
<http://www.technologystudent.com/despro2/toy6.html>

1f. The Pop-up booklet will have a front cover. The pop-up mechanism and character will be inside the booklet.

On the next page, in space 'A', draw a rough / outline version of the cover page to your popup booklet.

You will need a title and some detail regarding the illustrations.

Below are two sample layouts.

Total of 5 marks

SAMPLE

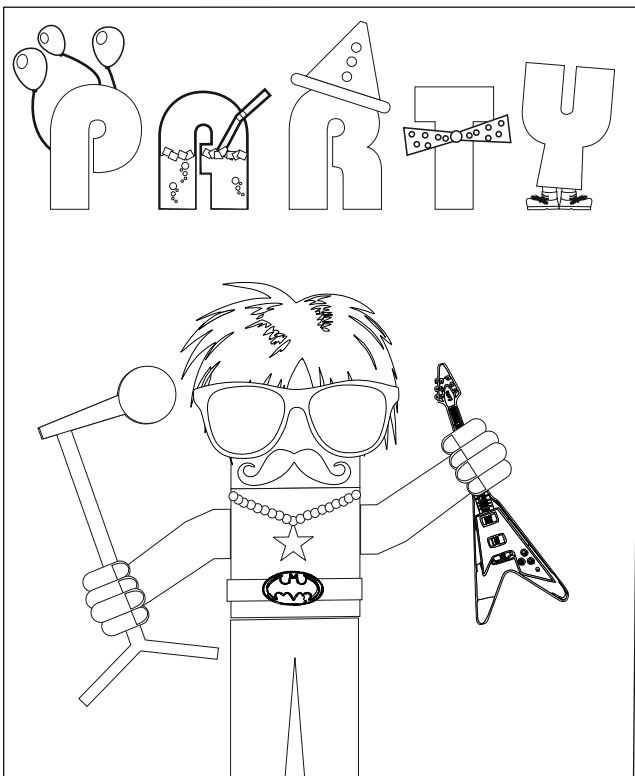

SAMPLE

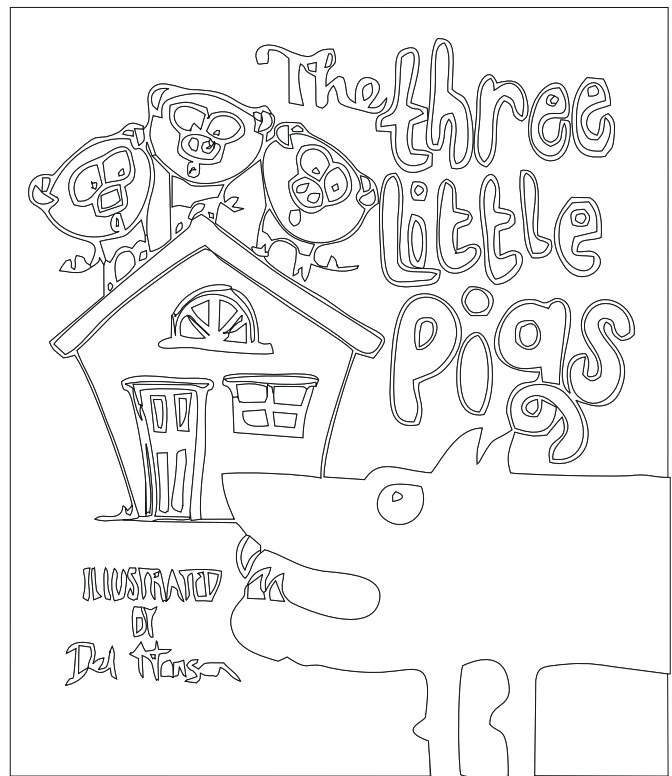

1-2 marks for basic design with some of the necessary features (such as title)

3-5 marks awarded for increase detail and visual impact (must be an outline version)

SPACE 'A' - ROUGH VERSION / OUTLINE

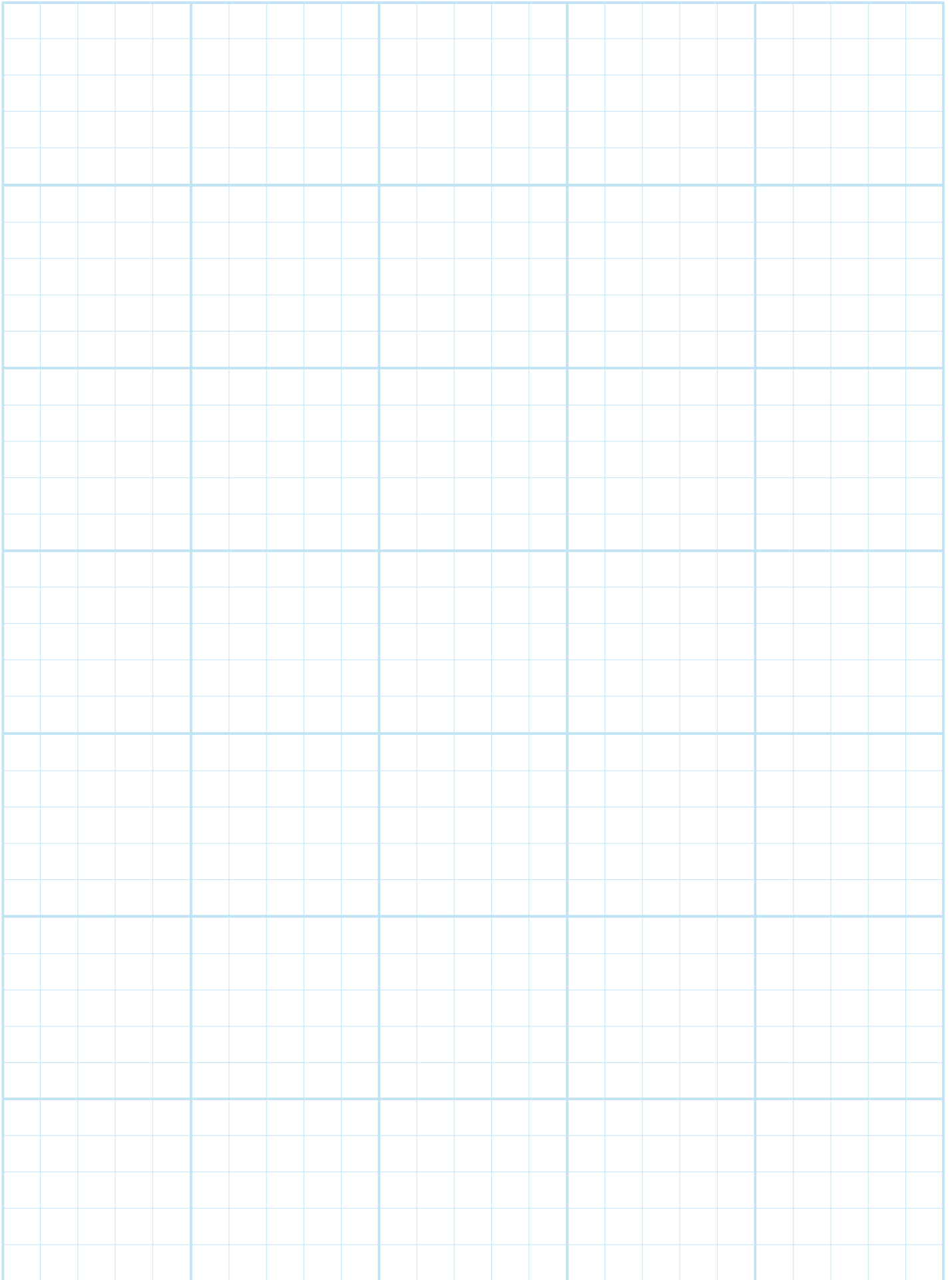

TO HELP YOU ANSWER THIS QUESTION, FOLLOW THE LINKS

<http://www.technologystudent.com/despro2/toy7.html>

1g. Evaluate your final pop-up fantasy character, against the design criteria shown below.

- ensure that the fantasy character represents the theme 'party' / 'fun'
- include a suitable colour scheme that supports the party / fun theme.
- your chosen character must appeal to children.
- show clearly, detail of the net(s) / development(s), that are folded to form the final character, minimising waste.

3 marks

1 mark for basic evaluation with limited reference to one or more criteria mentioned.

2 marks for two or more criteria mentioned in reasonable detail.

3 marks for including three or more of the criteria included in good detail.

Follow the link for detailed answer

SECTION B

TO HELP YOU ANSWER THIS QUESTION Follow the link below.

<http://www.technologystudent.com/designpro/quest1.htm>

Pictograms give the opportunity to show statistics graphically. The pictures/images in a pictogram should reflect the question that has been asked. For example, if you are trying to find the most popular colour of paint, the statistics could be presented as paint brushes, in a pictogram.

2. The table opposite shows the results of a survey. 100 people were asked to name the type of alarm system they were in most need of.

Using the grid below, draw a pictogram to represent the table of results. You will gain marks for your use of colour, images and imagination.

8 marks

ALARM TYPE	No OF PEOPLE
A BICYCLE	15
B BRIEF CASE	20
C DOOR	24
D PERSONAL ALARM	5
E CAR	7
F PICK-POCKET	10
G WINDOW	29
TOTAL	100

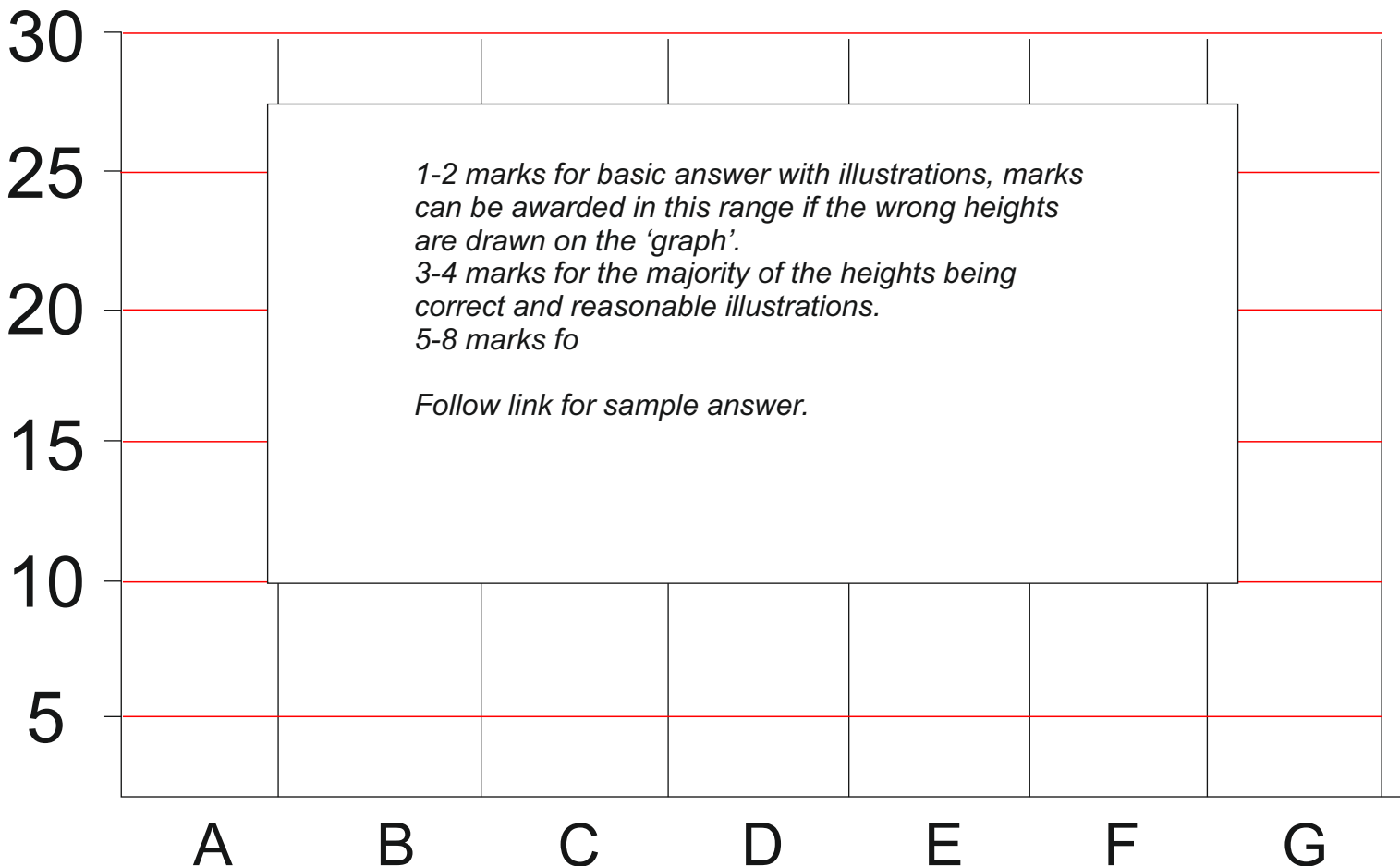

TO HELP YOU ANSWER THIS QUESTION Follow the links below.

<http://www.technologystudent.com/designpro/orthogrp1.html>

http://www.technologystudent.com/pdf15/orth1_answers.pdf

3. Complete the orthographic drawings of the 3D objects, by adding the missing lines. Remember, hidden detail is represented by a dotted line. The arrow 'X' indicates the front view. Arrow 'Y' indicates the side view. **4 x 2 marks**

FRONT

SIDE VIEW



3D DRAWING

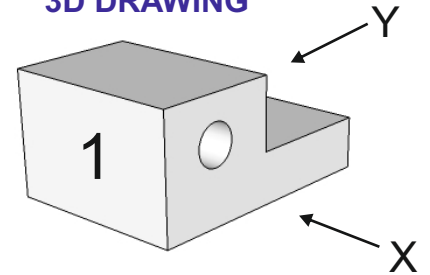

For each orthographic - 1 mark for an answer with some/limited correct positioning of lines / detail.

2 marks for fully correct answer.

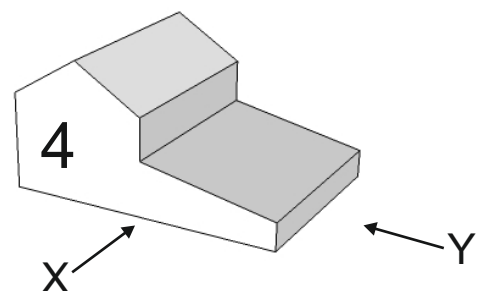
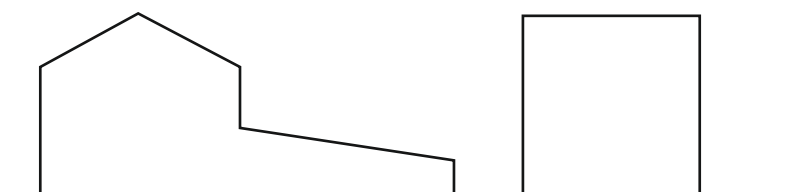
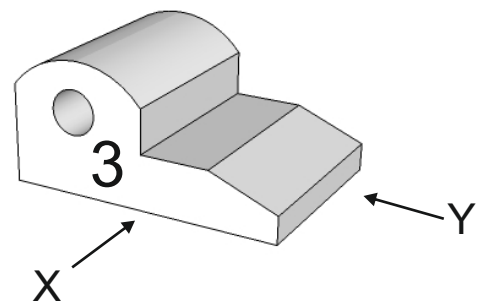
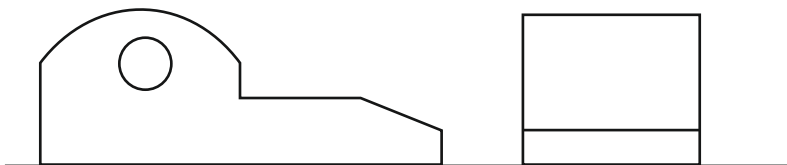
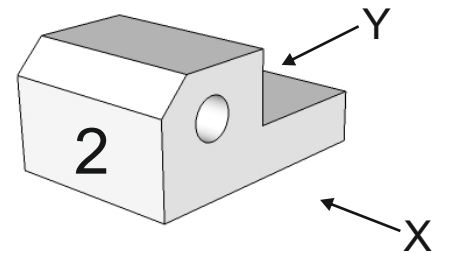
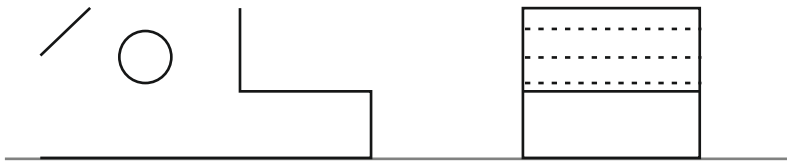

ANSWERS

FRONT AND SIDE VIEW

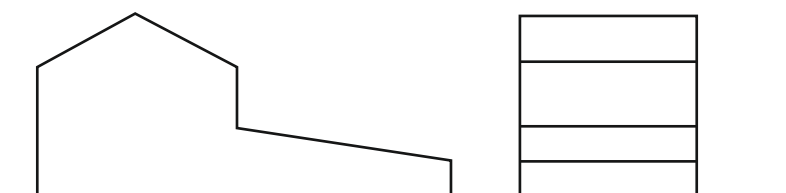
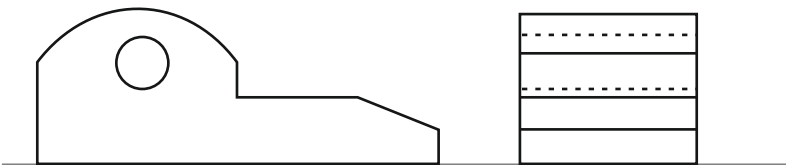
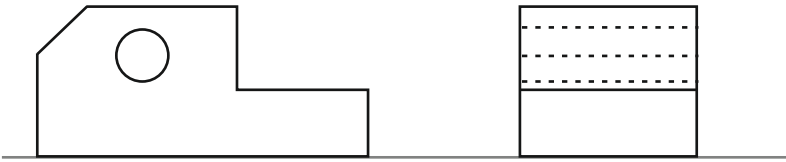

3D DRAWING

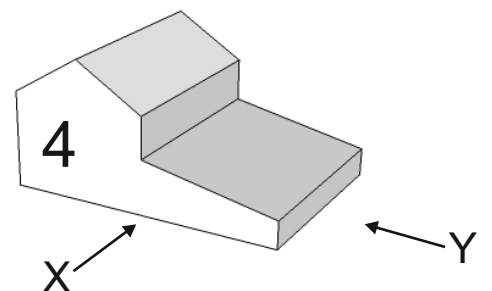
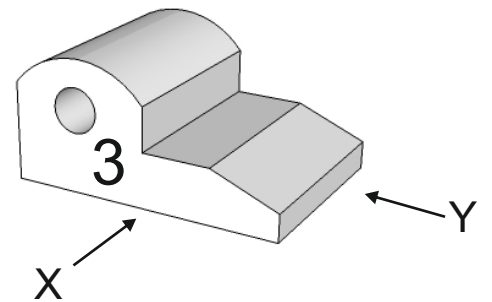
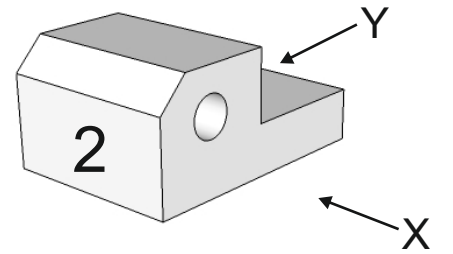
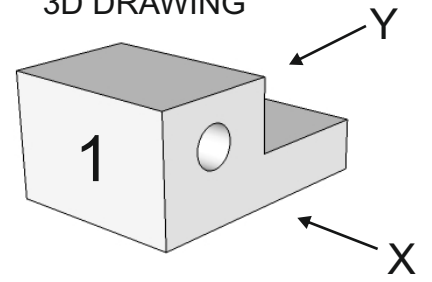

TO HELP YOU ANSWER THIS QUESTION Follow the links below.

<http://www.technologystudent.com/designpro/drawtec4.htm>

4. Adding colour to sketches often improves their final appearance.

Two bottles are shown below. Add colour to enhance their final presentation. An example of a completed colour scheme is seen opposite.

8 marks (2 x 4 marks)



For each illustration:

1 mark for limited application of colour. Rather inaccurate.

2 marks for increased accuracy of shade.

Up to an additional 2 marks for impact and realistic application of colour.

Follow link for sample answer.

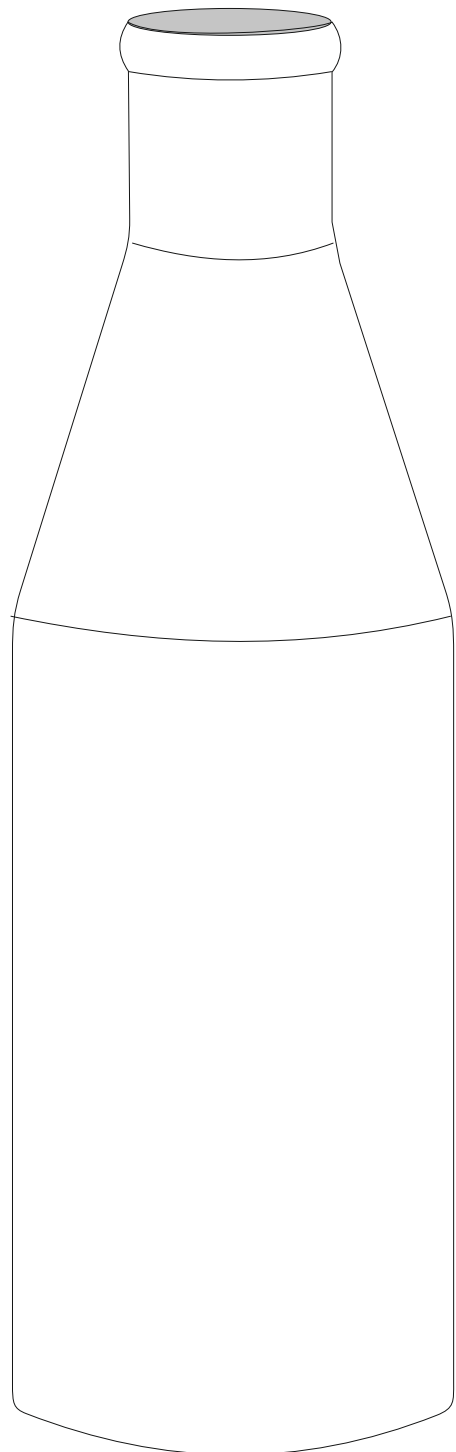
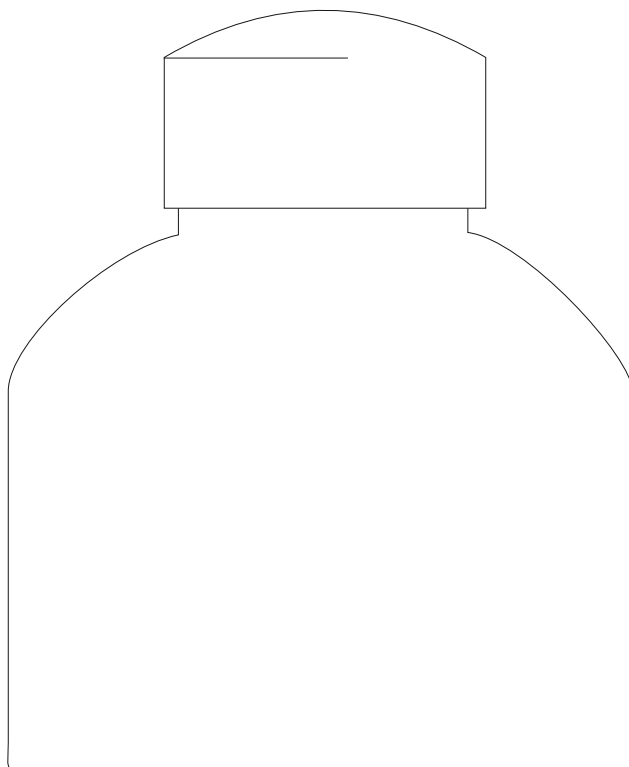

TO HELP YOU ANSWER THIS QUESTION Follow the link below.

<http://www.technologystudent.com/joints/aroma1.html>

WORLD ASSOCIATION OF TECHNOLOGY TEACHERS <https://www.facebook.com/groups/254963448192823/> www.technologystudent.com © 2018 V.Ryan © 2018

5a. Designers need an understanding of smart materials. Aroma Pigments have many practical applications. What are Aroma Pigments? **2 mark**

5b. Describe two practical applications of Aroma Pigments. **2 x 3 marks**

PRACTICAL APPLICATION 1:

*Follow link for sample answer.
1 mark for basic answer
2 marks for addition of some detail
3 marks for full detailed answer.*

PRACTICAL APPLICATION 1:

*Follow link for sample answer.
1 mark for basic answer
2 marks for addition of some detail
3 marks for full detailed answer.*

TO HELP YOU ANSWER
THIS QUESTION

Follow the links below.

<http://www.technologystudent.com/designpro/pricol1.htm>

6a. Name the three primary colours. **3 marks**

1 mark per correct colour - follow link for answer.

6b. Complete the table below by adding the missing colours. **3 marks**

1 mark per correct colour - follow link for answer.

YELLOW	+		=	GREEN
BLUE	+	RED	=	
	+	YELLOW	=	ORANGE

6c. What are secondary colours? **1 mark**

1 mark awarded for correct answer.

Follow the link for sample answer.

6d. The colour wheel drawn below is missing its colours. Add the correct colours using coloured pencils. The wheel should accurately represent a colour wheel. **3 marks**

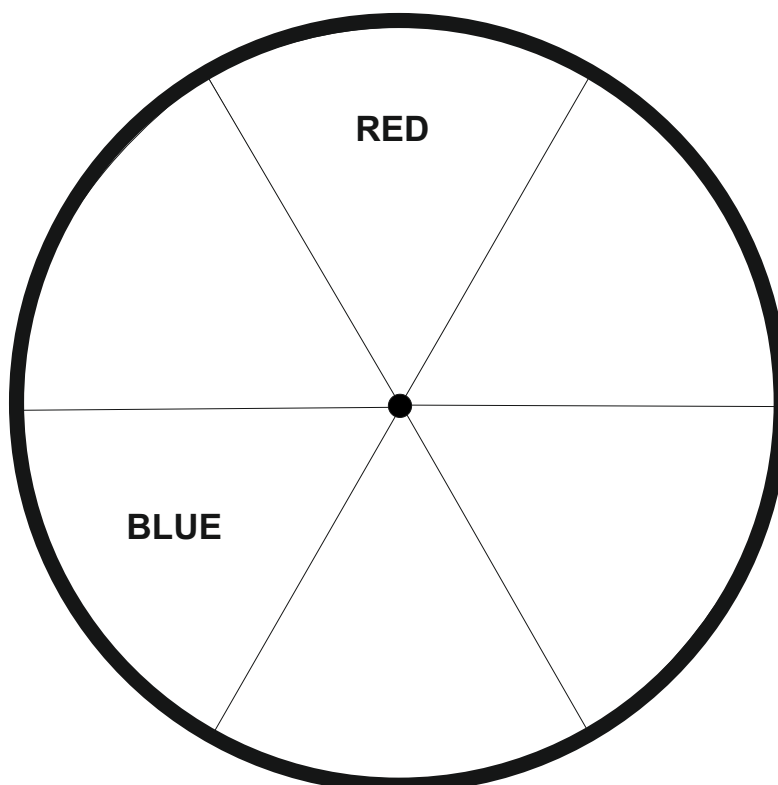

1 mark for up to 2 colours

2 marks for 3 colours

3 marks for 4 colours.

Follow the link for sample answer.

TO HELP YOU ANSWER THIS QUESTION Follow the links below.

<http://www.technologystudent.com/designpro/perhous2.htm>

WORLD ASSOCIATION OF TECHNOLOGY TEACHERS

<https://www.facebook.com/groups/254963448192823/>

www.technologystudent.com © 2018 V.Ryan © 2018

7. Complete the two point estimated perspective drawing of the single storey house.

Complete the outline of the house. **3 marks**

Add colour and shade. **3 marks**

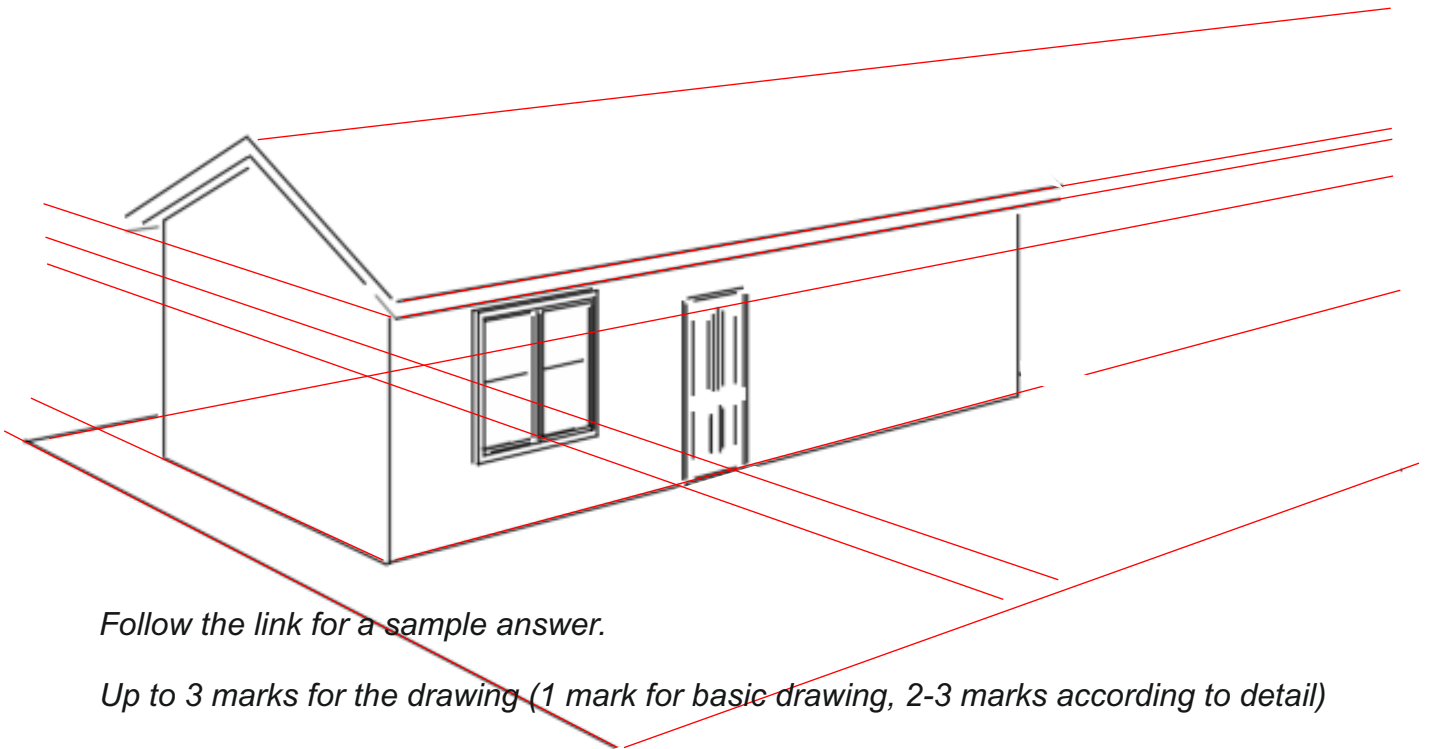
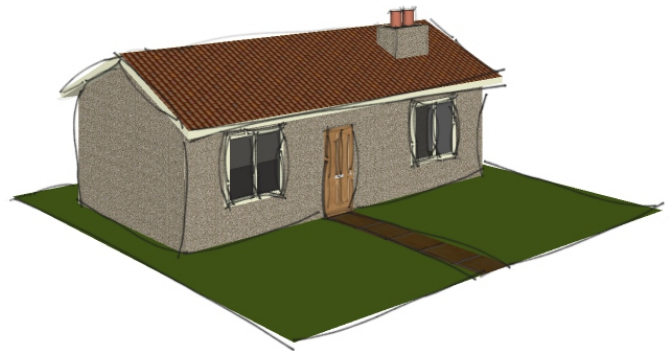
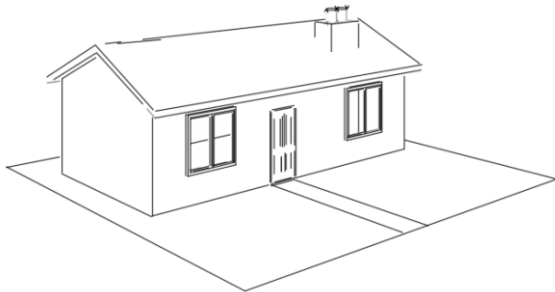

Follow the link for a sample answer.

Up to 3 marks for the drawing (1 mark for basic drawing, 2-3 marks according to detail)

In addition - Up to 3 marks for shading (1 mark for basic shading, 2-3 marks according to detail / level of shading)

TO HELP YOU ANSWER THIS QUESTION Follow the link below.

<http://www.technologystudent.com/prddes1/plannedob1.html>

<http://www.technologystudent.com/prddes1/plannedob2.html>

Designers need an understanding of Planned Obsolescence and Perceived Obsolescence.

8a. What is meant by the term **Planned Obsolescence? 4 marks**

1 mark per fact / correct point.

Follow the link for sample answer.

8b. What is meant by the term **Perceived Obsolescence? 4 marks**

1 mark per fact / correct point.

Follow the link for sample answer.

TO HELP YOU ANSWER THIS QUESTION Follow the link below.

http://www.technologystudent.com/despro_flsh/new_problem1.html

9a. Before designers spend time working on a solution to a design problem, they need to collect evidence, that the problem is one that is worth solving. How is this evidence collected? **2 marks**

For 1 mark - clear explanation of one method of collecting evidence (e.g. a survey / questionnaire)

2 marks for 2 techniques being clearly identified.

Follow link for sample answer.

TO HELP YOU ANSWER THIS QUESTION Follow the link below.

http://www.technologystudent.com/despro_flsh/focusres1.html

9b. Why is it important to carry out focussed analytical research of existing products, before designing a new /improved product? **2 marks**

1 mark - for one correct fact.

2 marks for 2 or more facts.

Follow the link for sample answer.

TO HELP YOU ANSWER THIS QUESTION Follow the links below.

http://www.technologystudent.com/despro_flsh/anmood1.html

<http://www.technologystudent.com/prddes1/moody1.html>

9c. What is a moodboard? **1 mark**

1 mark for a clear statement - follow the link for sample answer.

9d. How can a moodboard be used for analytical research? **2 marks**

1 mark for each correct use of a moodboard in analytical research.

Follow the link for sample answer.

TO HELP YOU ANSWER THIS QUESTION Follow the links below.

<http://www.technologystudent.com/despro2/crdpap2.htm>

<http://www.technologystudent.com/despro2/pkmat1.htm>



http://www.technologystudent.com/despro_flsh/laminate1.html

WORLD ASSOCIATION OF TECHNOLOGY TEACHERS

<https://www.facebook.com/groups/254963448192823/>

www.technologystudent.com © 2018 V.Ryan © 2018

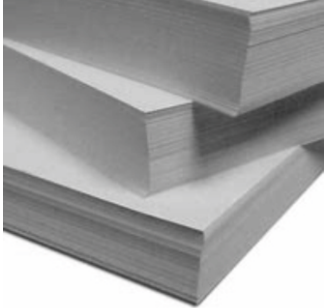
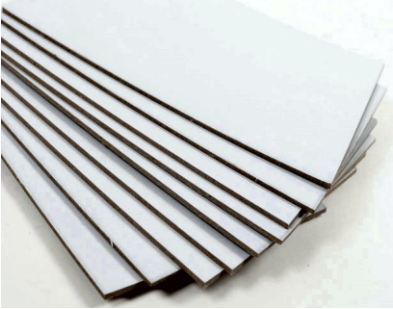
10. For each material listed below, describe the material and give one practical application. An example has been completed for you. **2 x 7 marks (14 marks)**

MATERIAL	DESCRIPTION AND PRACTICAL APPLICATION
<p data-bbox="220 555 627 595">CARTRIDGE PAPER</p> 	<p data-bbox="815 591 1485 880"><i>Used for general drawing and photocopying. It is good quality and generally 100 to 135g in thickness. This paper is used for design work, sketching and letter writing. It will take colour from felt pens, without leaking/bleeding through to the paper.</i></p>
<p data-bbox="248 969 584 1010">DUPLEX BOARD</p> 	<p data-bbox="839 1068 1090 1099"><i>For each answer:</i></p> <p data-bbox="839 1137 1414 1211"><i>1 mark for an adequate description 1 mark for a correct practical application</i></p> <p data-bbox="839 1245 1318 1276"><i>Follow the link for sample answer</i></p>
<p data-bbox="204 1384 667 1424">CORRUGATED BOARD</p> 	<p data-bbox="839 1473 1090 1505"><i>For each answer:</i></p> <p data-bbox="839 1543 1414 1617"><i>1 mark for an adequate description 1 mark for a correct practical application</i></p> <p data-bbox="839 1650 1318 1682"><i>Follow the link for sample answer</i></p>
<p data-bbox="248 1798 643 1839">FOIL LINED BOARD</p> 	<p data-bbox="839 1917 1090 1948"><i>For each answer:</i></p> <p data-bbox="839 1986 1414 2060"><i>1 mark for an adequate description 1 mark for a correct practical application</i></p> <p data-bbox="839 2094 1318 2125"><i>Follow the link for sample answer</i></p>

TO HELP YOU ANSWER THIS QUESTION Follow the links below.

<http://www.technologystudent.com/despro2/crdpap2.htm>



<http://www.technologystudent.com/despro2/pkmat1.htm>

http://www.technologystudent.com/despro_flsh/laminate1.html

WORLD ASSOCIATION OF TECHNOLOGY TEACHERS

<https://www.facebook.com/groups/254963448192823/>

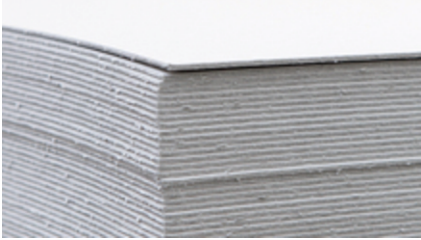
www.technologystudent.com © 2018 V.Ryan © 2018

MATERIAL	DESCRIPTION AND PRACTICAL APPLICATION
<p data-bbox="245 445 596 488">TRACING PAPER</p> 	<p data-bbox="852 553 1102 586"><i>For each answer:</i></p> <p data-bbox="852 622 1426 696"><i>1 mark for an adequate description 1 mark for a correct practical application</i></p> <p data-bbox="852 730 1331 763"><i>Follow the link for sample answer</i></p>
<p data-bbox="197 860 639 902">SOLID WHITE BOARD</p> 	<p data-bbox="836 983 1086 1016"><i>For each answer:</i></p> <p data-bbox="836 1052 1410 1126"><i>1 mark for an adequate description 1 mark for a correct practical application</i></p> <p data-bbox="836 1160 1315 1193"><i>Follow the link for sample answer</i></p>
<p data-bbox="309 1285 564 1328">ALUMINIUM</p> 	<p data-bbox="836 1391 1086 1424"><i>For each answer:</i></p> <p data-bbox="836 1460 1410 1534"><i>1 mark for an adequate description 1 mark for a correct practical application</i></p> <p data-bbox="836 1568 1315 1601"><i>Follow the link for sample answer</i></p>
<p data-bbox="248 1688 628 1731">LAMINATED CARD</p> 	<p data-bbox="836 1789 1086 1823"><i>For each answer:</i></p> <p data-bbox="836 1859 1410 1933"><i>1 mark for an adequate description 1 mark for a correct practical application</i></p> <p data-bbox="836 1966 1315 2000"><i>Follow the link for sample answer</i></p>

TO HELP YOU ANSWER
THIS QUESTION

Follow the link below.
<http://www.technologystudent.com/rmprp07/glidir2.html>

11a. Die Cutting is an important industrial process. Using notes and a sketch(s), explain this process. **5 marks**

1 mark for only a sketch or notes

2-3 marks for both notes and sketch(s) in limited detail.

3-5 marks for increased detail. Teacher discretion required.

Follow the link for sample answer.

TO HELP YOU ANSWER
THIS QUESTION

Follow the link below.
<http://www.technologystudent.com/despro2/prneff4.htm>

11b. Embossing is a printing effect. Using notes and a sketch(s), explain the process. **5 marks**

1 mark for only a sketch or notes

2-3 marks for both notes and sketch(s) in limited detail.

3-5 marks for increased detail. Teacher discretion required.

Follow the link for sample answer.

TO HELP YOU ANSWER
THIS QUESTION

Follow the link below.
<http://www.technologystudent.com/designpro/prtpro5.htm>

12a. An incomplete sketch of the printing process called **lithography** is drawn below. Complete the sketch by adding the missing parts and labelling the final drawing. Most of the important parts are listed : **3 marks**

PRINTING PLATE - WATER - IMPRESSION CYLINDER - INK - BLANKET CYLINDER

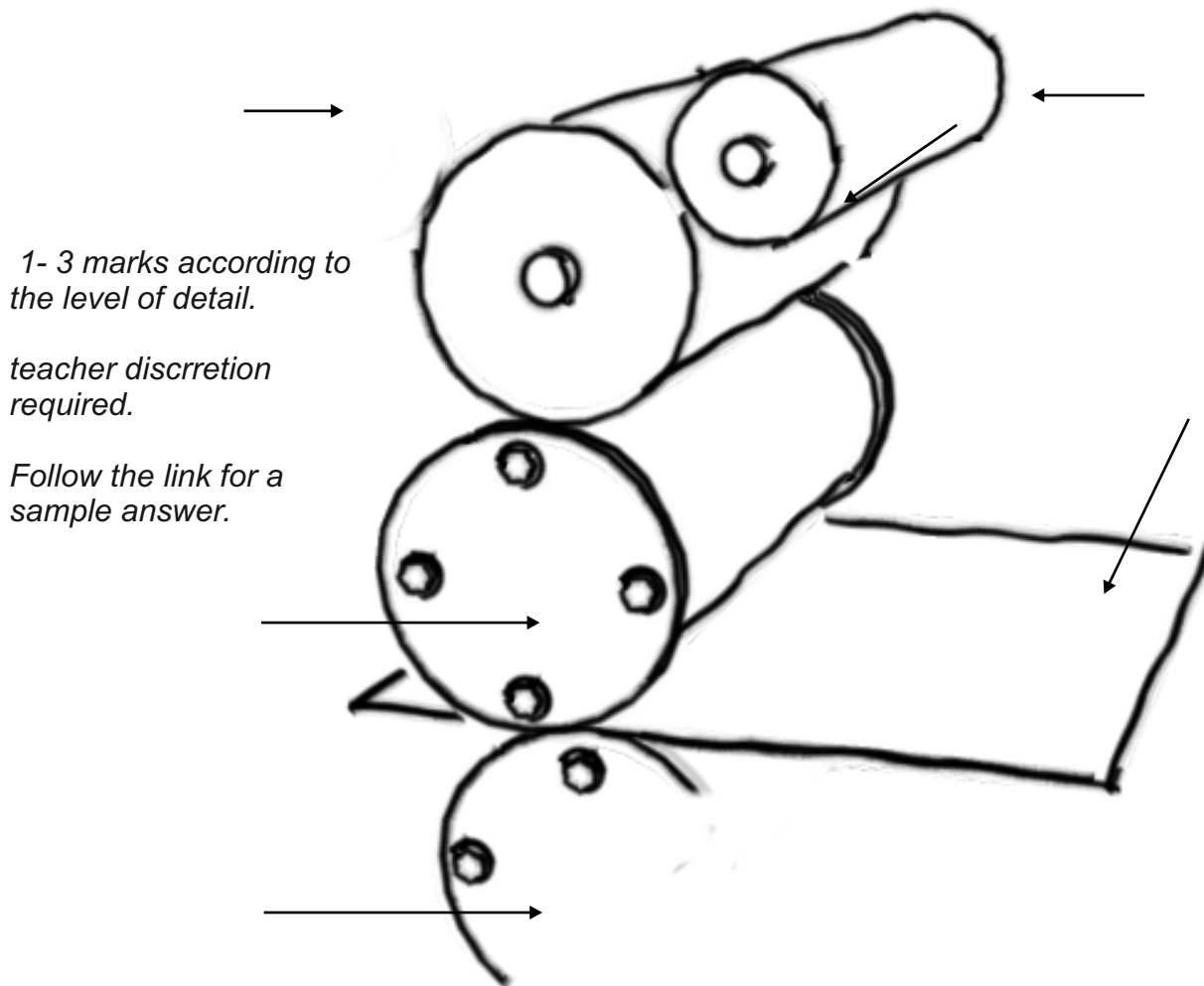

12b. Explain how lithography works, as shown by the sketch above. **2 marks**

1 mark for basic explanation of the process.

2 marks for increased detail.

Follow the link for a sample answer.

This question is focussed on materials and also symbols.

TO HELP YOU ANSWER
THIS QUESTION

http://www.technologystudent.com/despro_fish/eurosym1.html
<http://www.technologystudent.com/despro2/mrsym1.htm>

13. Three important symbols are seen below. Complete the table by adding the symbol letter to the correct description. **3 marks**

A



B



C



LETTER	DESCRIPTION
B	Found on packaging that contains potentially harmful contents. For example, a tin of paint stripper.
C	In the past many products were tested on animals to ensure that they were safe for use by humans. Today this type of testing is regarded as being inhumane to animals as it inflicts unnecessary pain and suffering. Products carrying this type of symbol have not been tested on animals.
A	The Ecolable is a scheme managed by the European Union (see symbol opposite). It was established in 1992 and aims to promote products and services that are environmentally friendly.

TO HELP YOU ANSWER
THIS QUESTION

<http://www.technologystudent.com/prddes1/advert1.html>

14a. Advertising is one way of promoting a product and increasing sales. Give four reasons how advertising helps to promote products. **4 marks**

REASON 1:

REASON 2:

1 mark per correctly identified reason.

Follow the link for sample answers.

REASON 3:

REASON 4:

TO HELP YOU ANSWER
THIS QUESTION

<http://www.technologystudent.com/prddes1/advert2.html>

14b. Describe how advertising has been used to promote a product of your choice. **3 marks**

PRODUCT NAME:

Product must be named to gain any marks

DESCRIPTION:

1 mark for basic answer with one fact / way advertising has been used.

2 marks more detailed answer with 2 facts / ways advertising has been used.

3 marks for detailed explanation of 3 ways of advertising a product.

Follow the link for detailed examples of advertising.

TO HELP YOU ANSWER
THIS QUESTION

http://www.technologystudent.com/despro_flesh/charity10.html

14c. The charity collection box below is flat packed. It is left 'flat' outside a household and the owners form it into a carrying box (with handle). The box is filled with unwanted clothes and left on the doorstep, for the charity to collect later.

Why is CORRUGATED PLASTIC (POLYPROPYLENE) a suitable material for this product? **3 marks**

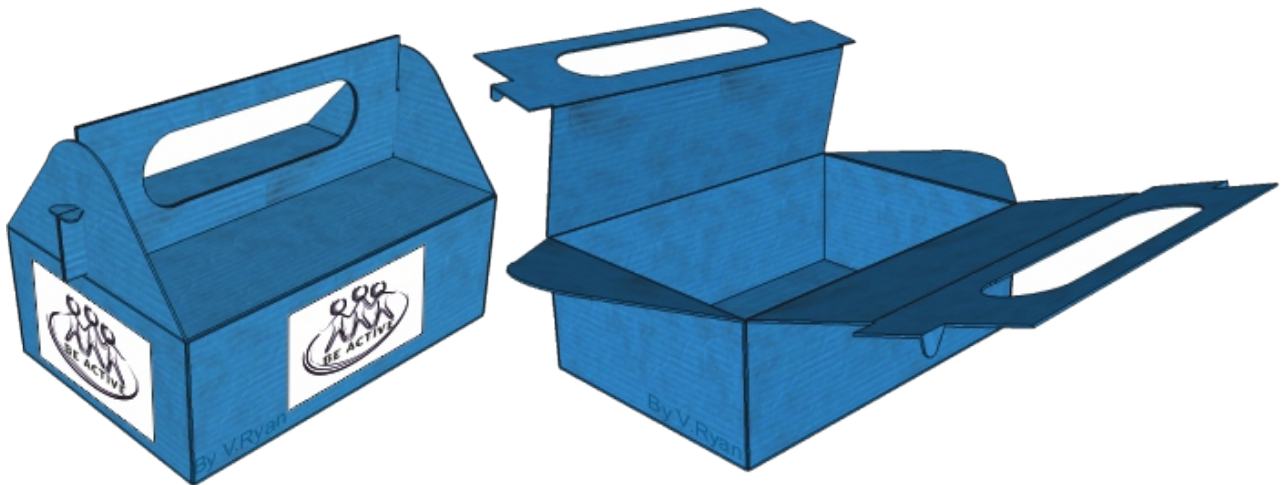

Follow the link for sample answer.

1 mark for 1 fact / correctly identified suitability

2 marks for 2 facts / correctly identified suitability.

3 marks for 3 facts / correctly identified suitability