

# INTRODUCTION TO FORGEWORK - PART FOUR

WORLD ASSOCIATION OF TECHNOLOGY TEACHERS

<https://www.facebook.com/groups/254963448192823/>

[www.technologystudent.com](http://www.technologystudent.com) © 2020 V.Ryan © 2020

## SCROLL WORK

FLARE CREATED

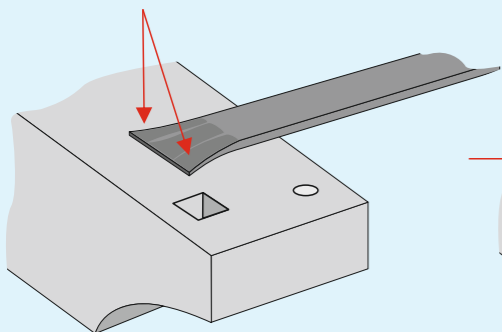

BEND THE FLARE TO A 90 DEGREE ANGLE

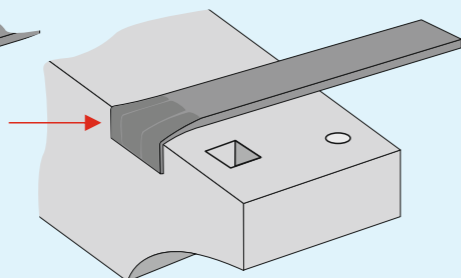

HAMMER THE FLARE BACK ON ITSELF

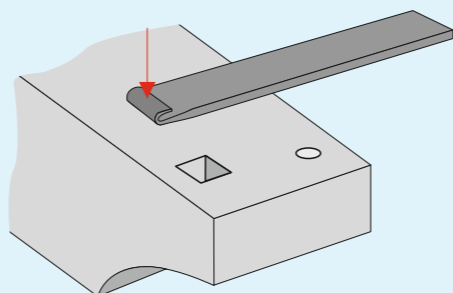

SELECT A SUITABLE SCROLLING JIG

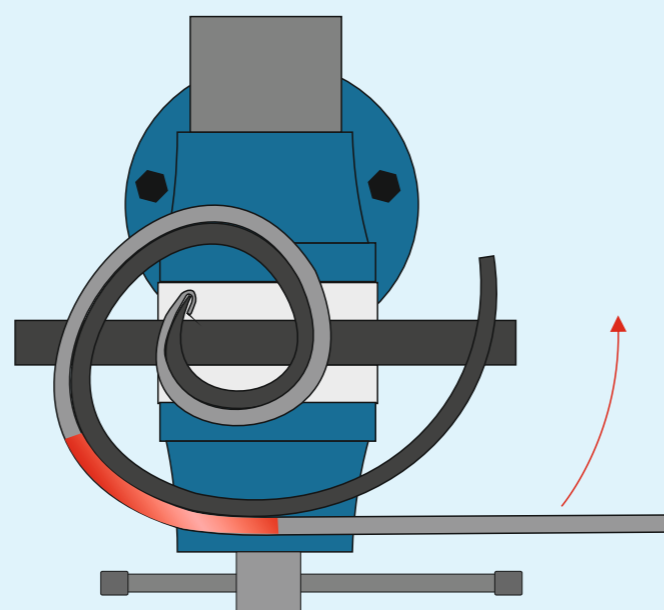
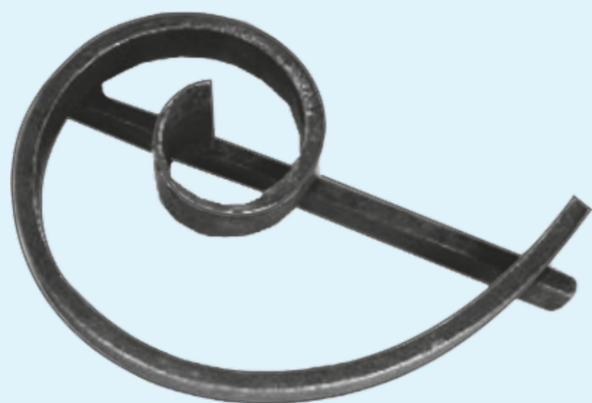

## USING A PUNCH - TO PUNCH A HOLE

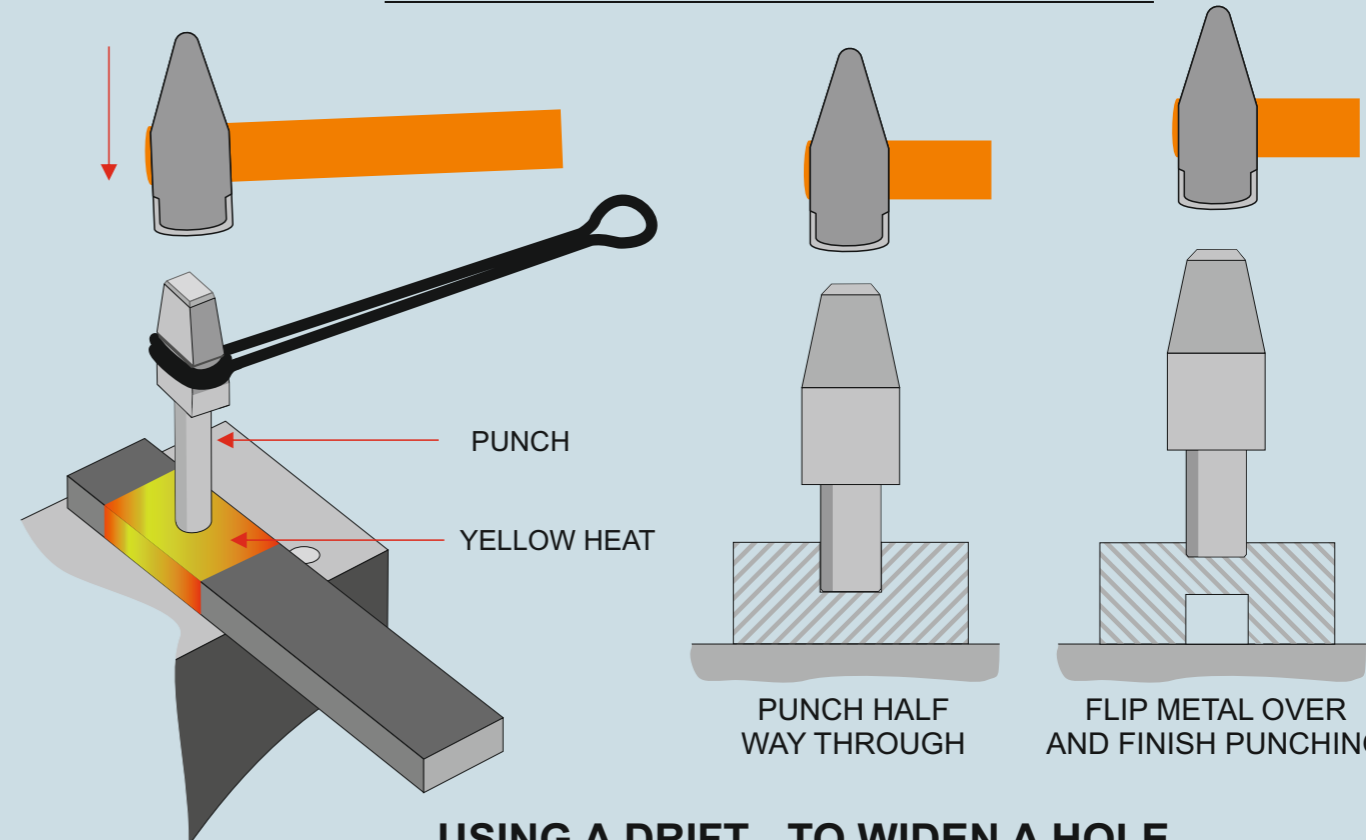

## USING A DRIFT - TO WIDEN A HOLE

