

MECHANISMS INFORMATION / WORKSHEETS

V.Ryan © 2000 - 2009

On behalf of The World Association of Technology Teachers

W.A.T.T.



World Association of Technology Teachers

This exercise can be printed and used by teachers and students. It is recommended that you view the website (www.technologystudent.com) before attempting the design sheet .

THESE MATERIALS CAN BE PRINTED AND USED BY TEACHERS AND STUDENTS.
THEY MUST NOT BE EDITED IN ANY WAY OR PLACED ON ANY OTHER MEDIA INCLUDING WEB SITES AND INTRANETS.
NOT FOR COMMERCIAL USE.
THIS WORK IS PROTECTED BY COPYRIGHT LAW.
IT IS ILLEGAL TO DISPLAY THIS WORK ON ANY WEBSITE/MEDIA STORAGE OTHER THAN www.technologystudent.com

FLAT PLATE CAMS

V.Ryan © 2009 World Association of Technology Teachers

In the space below draw a simple example of a flat plate cam and its follower. Label important parts and add notes that explain how it works.

NOTES

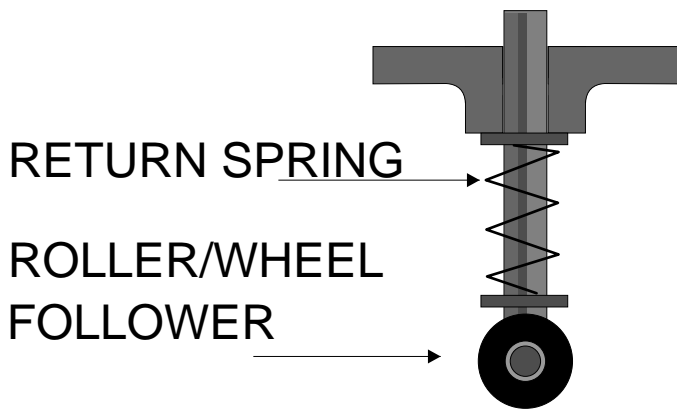

Roller followers are normally used with flat plate cams. Why is this the case?

The roller follower seen above has a return spring. Why is this often required?

In the space below draw a practical application of a plate cam and follower(s). Add explanatory notes.

NOTES
