

USING TAPS TO PRODUCE INTERNAL SCREW THREADS

TRY THE FREE MOBILE INTERACTIVE PDF APPS FOUND AT www.technologystudent.com - FOR ALL YOUR ENGINEERING AND TECHNOLOGY NEEDS

AMERICAN TYPE TAP WRENCH



BAR TYPE TAP WRENCH



**REMEMBER !
CUTTING COMPOUND**



**MOST COMMON METRIC
TAPPING DRILL SIZES**

METRIC SIZE (M)	TAPPING DRILL SIZE
2mm M2	1.6mm
3mm M3	2.5mm
4mm M4	3.3mm
5mm M5	4.2mm
6mm M6	5.0mm
8mm M8	6.8mm
10mm M10	8.5mm
12mm M12	10.2mm
14mm M14	12.0mm
16mm M16	14.0mm
18mm M18	15.5mm
20mm M20	17.5mm

TAPER TAP

INTERMEDIATE TAP

PLUG TAP

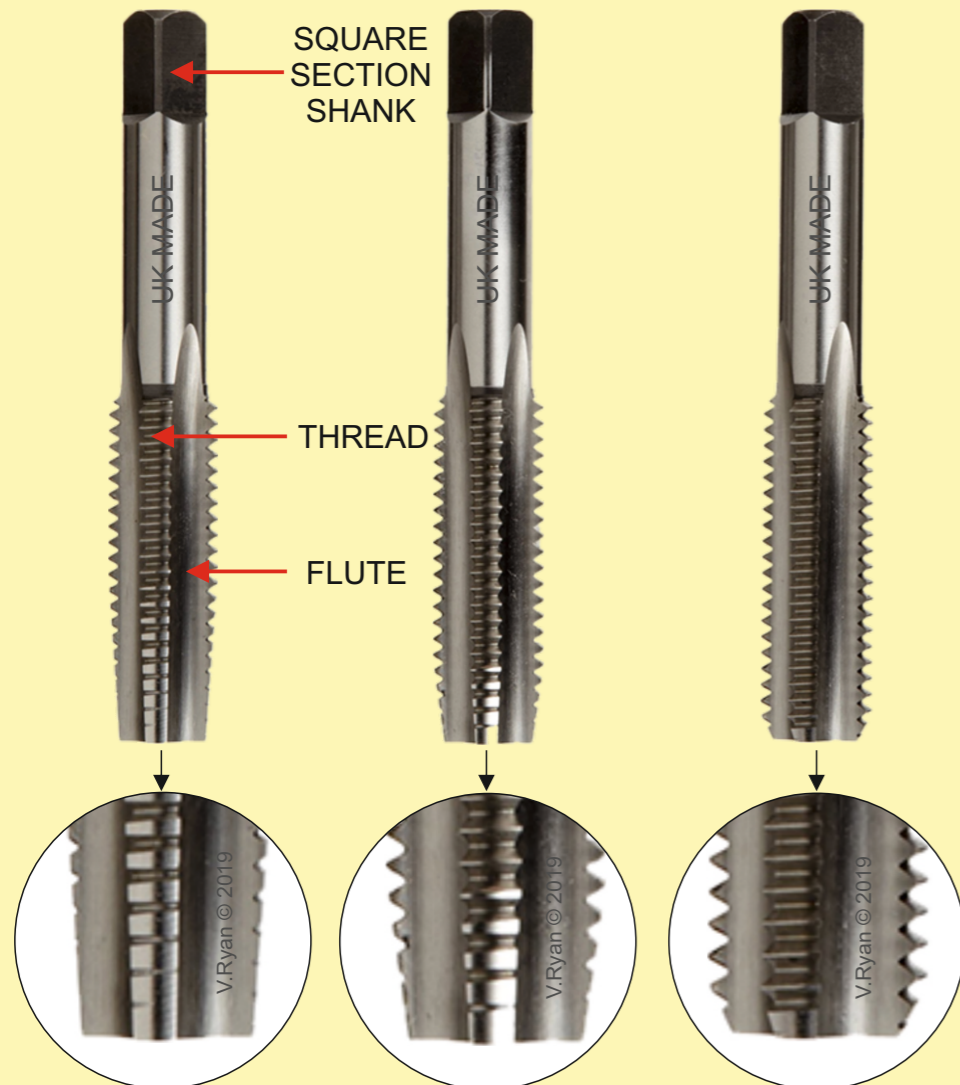

THREADING A THROUGH HOLE

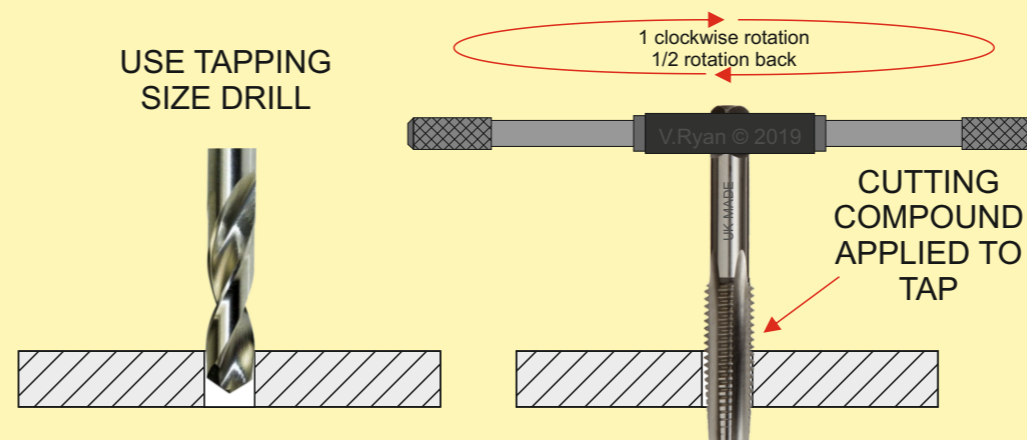

THREADING A BLIND HOLE

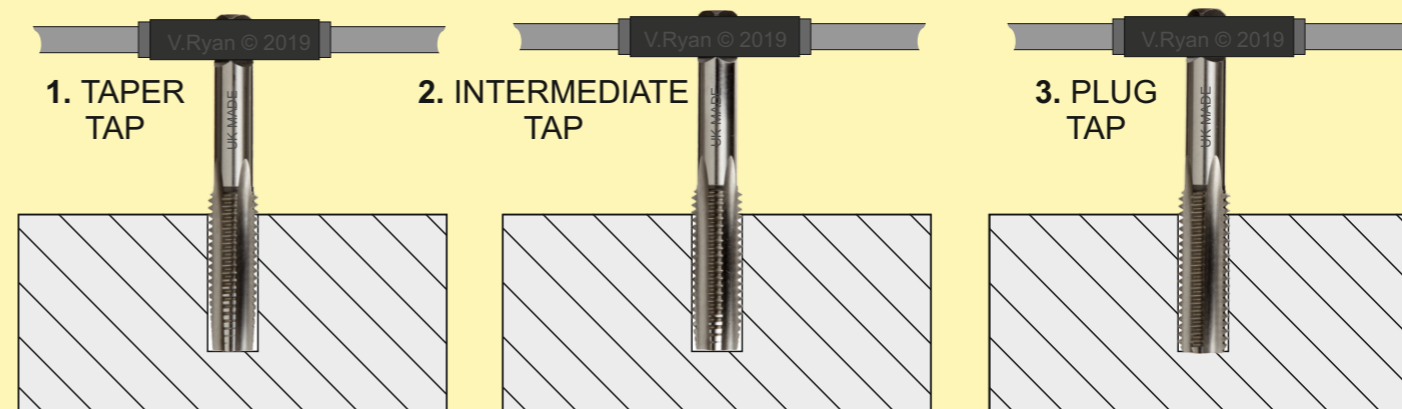

TRY THE FREE MOBILE INTERACTIVE PDF APPS FOUND AT www.technologystudent.com - FOR ALL YOUR ENGINEERING AND TECHNOLOGY NEEDS

USING DIES TO PRODUCE EXTERNAL SCREW THREADS

TRY THE FREE MOBILE INTERACTIVE PDF APPS FOUND AT www.technologystudent.com - FOR ALL YOUR ENGINEERING AND TECHNOLOGY NEEDS

THE STOCK (DIE HOLDER)

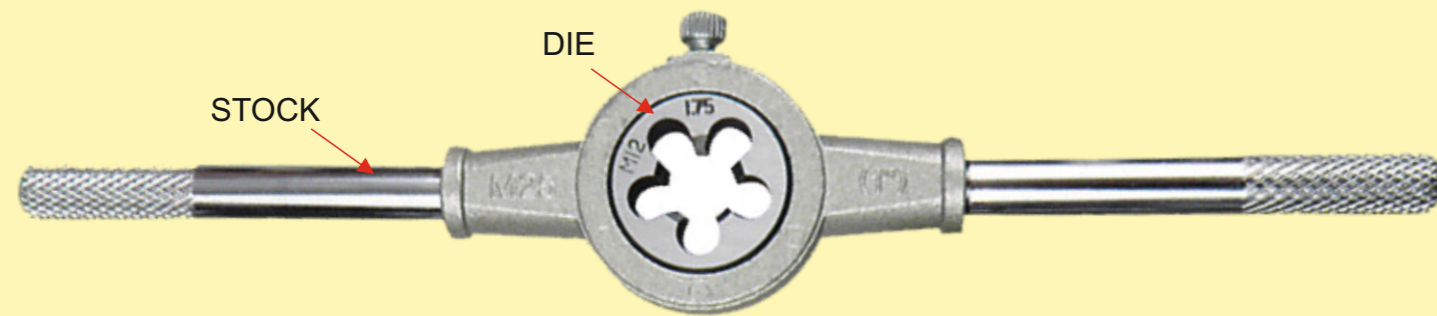

ADJUSTING SCREWS

ALTERNATIVE STOCK WITH A CENTRAL ADJUSTING SCREW AND TWO OUTER SCREWS

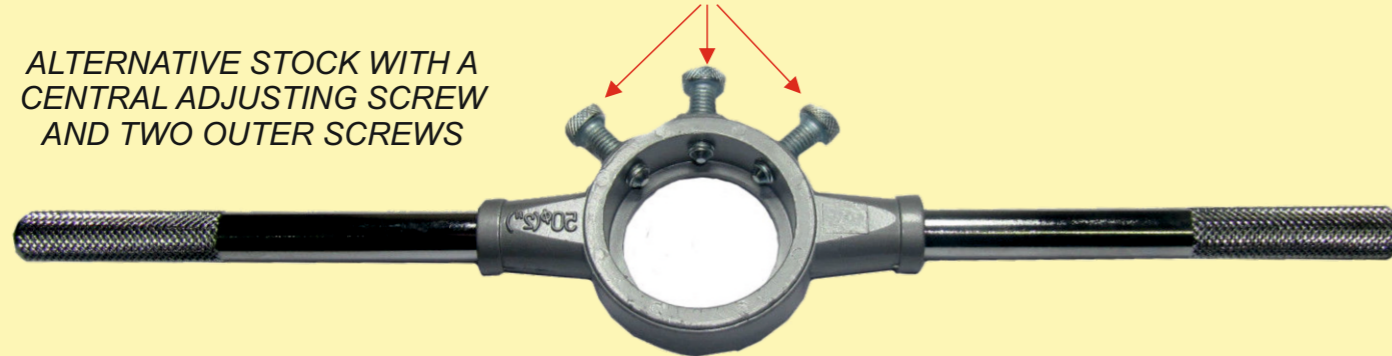

REMEMBER ! CUTTING COMPOUND



CIRCULAR SPLIT DIE

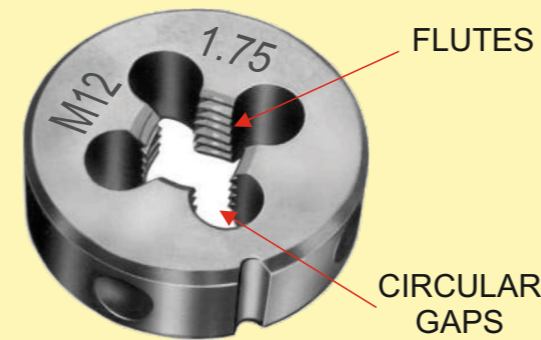

CUTTING AN EXTERNAL THREAD

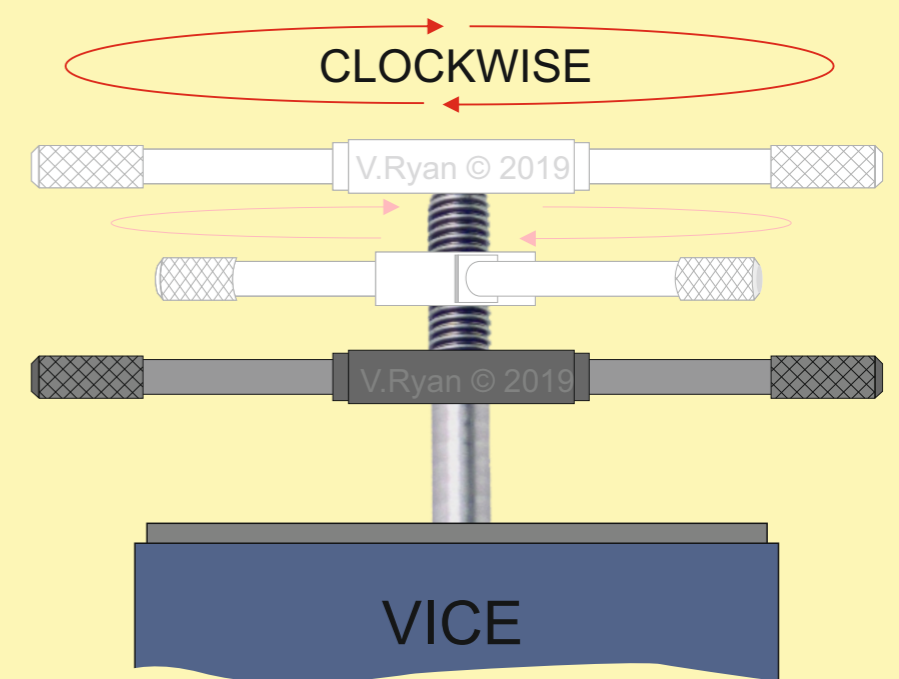

USING A STOCK WITH THE ASSISTANCE OF THE LATHE

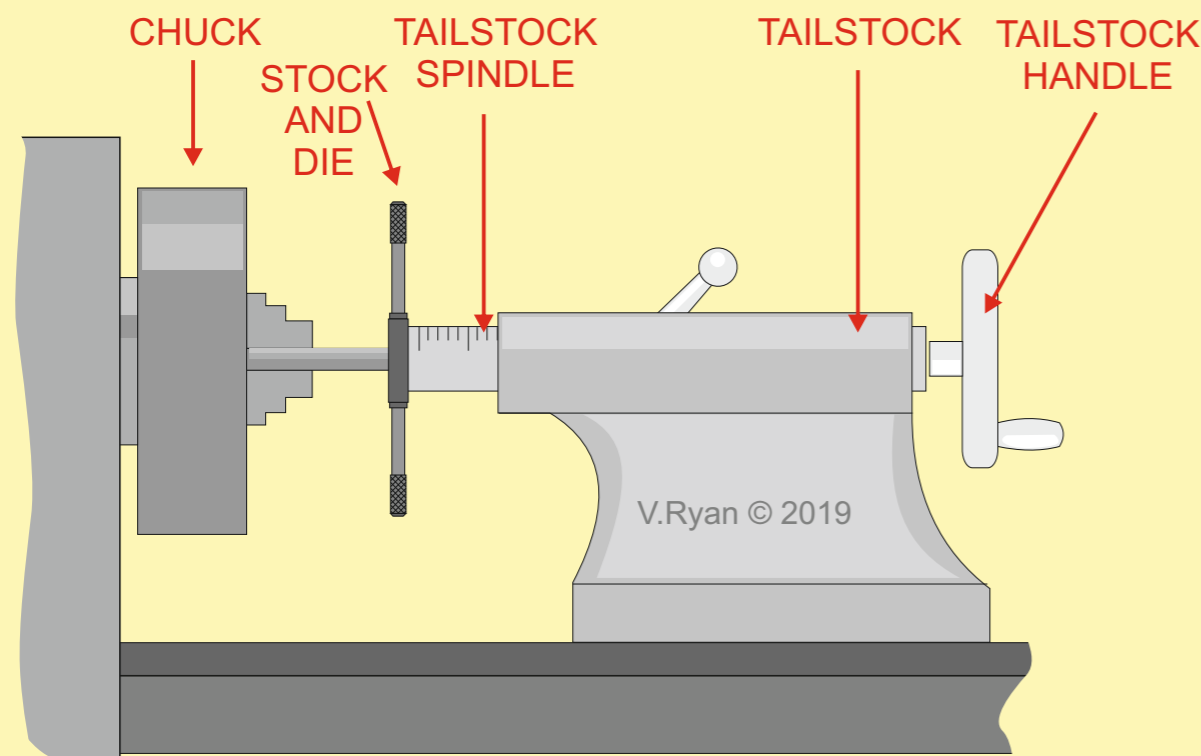

USING A TAILSTOCK DIE HOLDER WITH THE ASSISTANCE OF THE LATHE

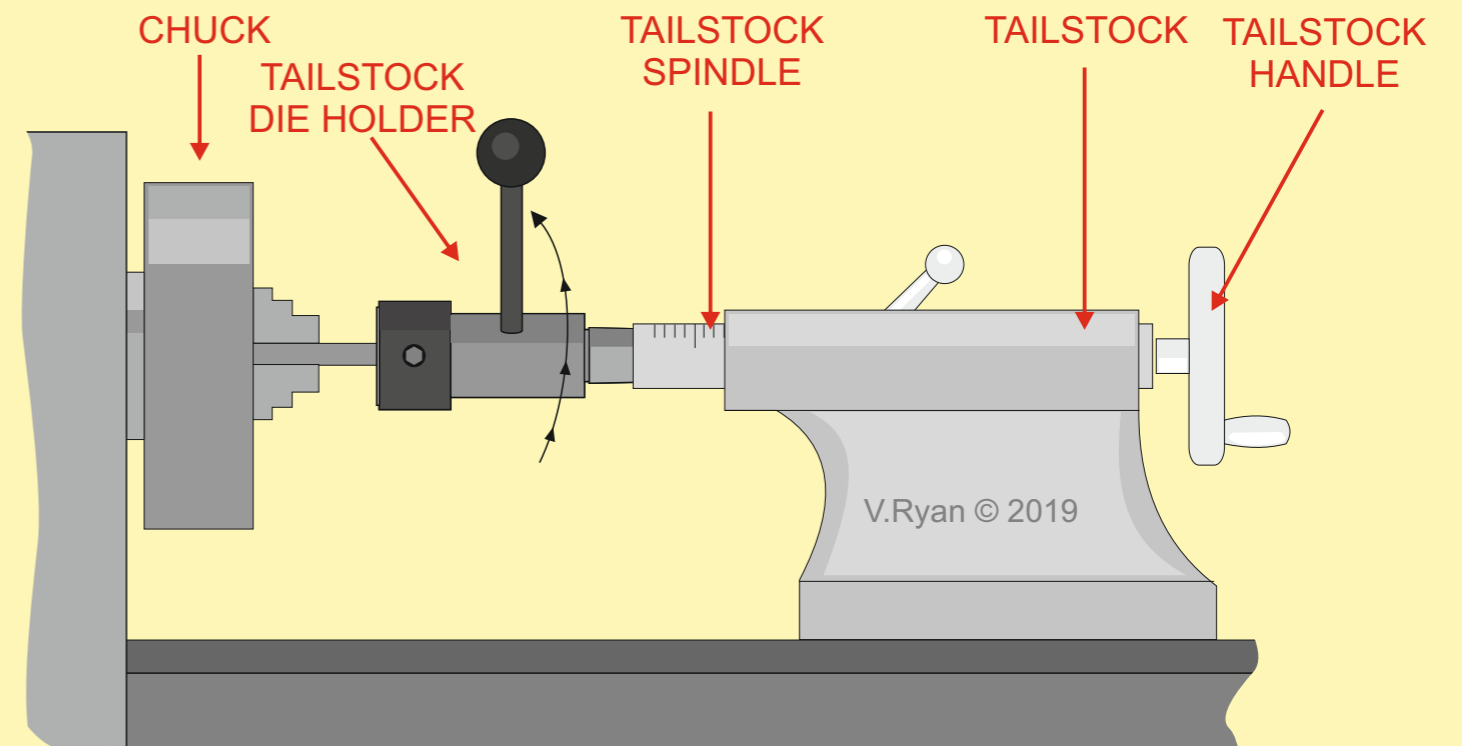

TRY THE FREE MOBILE INTERACTIVE PDF APPS FOUND AT www.technologystudent.com - FOR ALL YOUR ENGINEERING AND TECHNOLOGY NEEDS