

THE HAND DRILL

FRONT VIEW

BACK VIEW

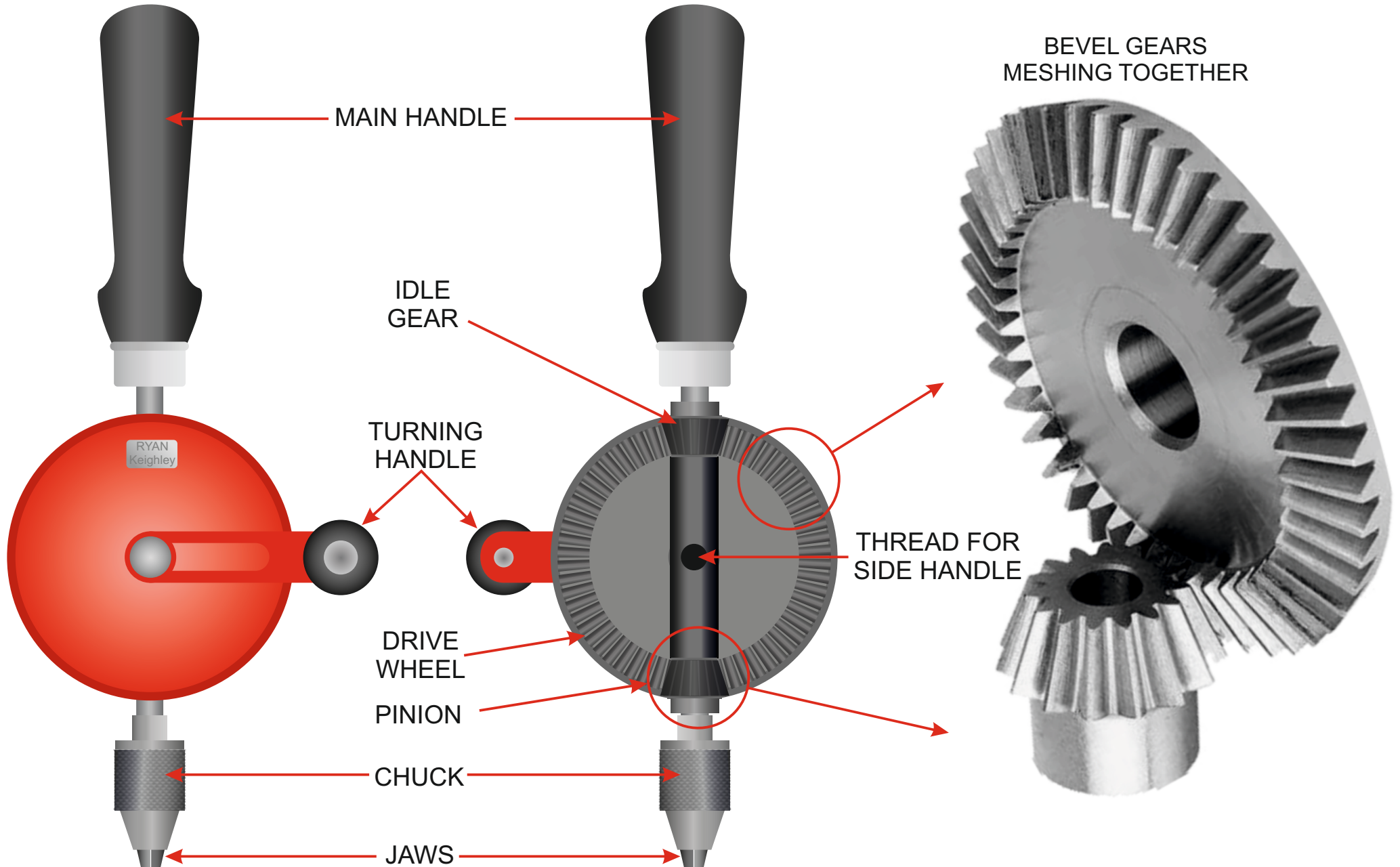

HOW TO USE THE HAND DRILL

It is always a good idea to clamp the material being drilled, to a workbench.
The hand drill is held vertically. One hand holds the handle at the top and the second hand rotates the other handle, in a clockwise direction. This turns the chuck and drill bit. Only light pressure should be used to push down on the hand drill, if a lot of pressure is needed the drill bit is probably blunt (change it for a sharp drill bit).

