

# SINGLE POINT PERSPECTIVE EXERCISE - 3

V.Ryan © 2000 - 2008

On behalf of The World Association of Technology Teachers

## W.A.T.T.

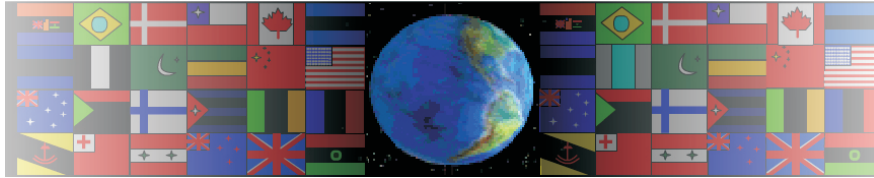

World Association of Technology Teachers

The 'Perspective Exercise' can be printed and used by teachers and students. It is recommended that you view the website section 'Graphics' ([www.technologystudent.com](http://www.technologystudent.com)) before attempting the design sheet .

THESE MATERIALS CAN BE PRINTED AND USED BY TEACHERS AND STUDENTS.  
THEY MUST NOT BE EDITED IN ANY WAY OR PLACED ON ANY OTHER MEDIA INCLUDING WEB SITES AND INTRANETS.  
NOT FOR COMMERCIAL USE.  
THIS WORK IS PROTECTED BY COPYRIGHT LAW.  
IT IS ILLEGAL TO HAVE THIS WORK DISPLAYED ON ANY WEBSITE/MEDIA STORAGE OTHER THAN [www.technologystudent.com](http://www.technologystudent.com)

# EXAMPLE OF SINGLE POINT PERSPECTIVE

V.Ryan © 2008 World Association of Technology Teachers

Read and practice the work on the earlier sheets covering single point perspective before attempting this sheet. Draw the chair shown below, following the basic instructions alongside each diagram. The chair below is manufactured from round section steel tube. This makes it a little easier to draw in perspective than regular square section material.

## ROUND SECTION STEEL TUBE CHAIR

VP X

1. Draw the side view of a chair and mark the single vanishing point with an X. Note the position of the vanishing point. It has been placed on the left hand side so that the seat of the chair can be seen when the perspective drawing is complete. You may need to experiment a little with the position of the vanishing until you find what you consider to be the right place.

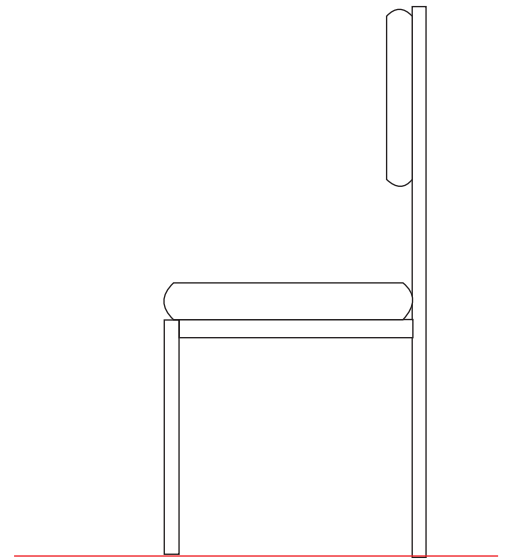

2. Draw faint lines from each corner/edge of the chair projecting them back to the vanishing point.

Notice how the top and bottom of each leg has been shaped to give the impression of curved surfaces (round section steel tube)

Add the width to the chair and shade/colour.

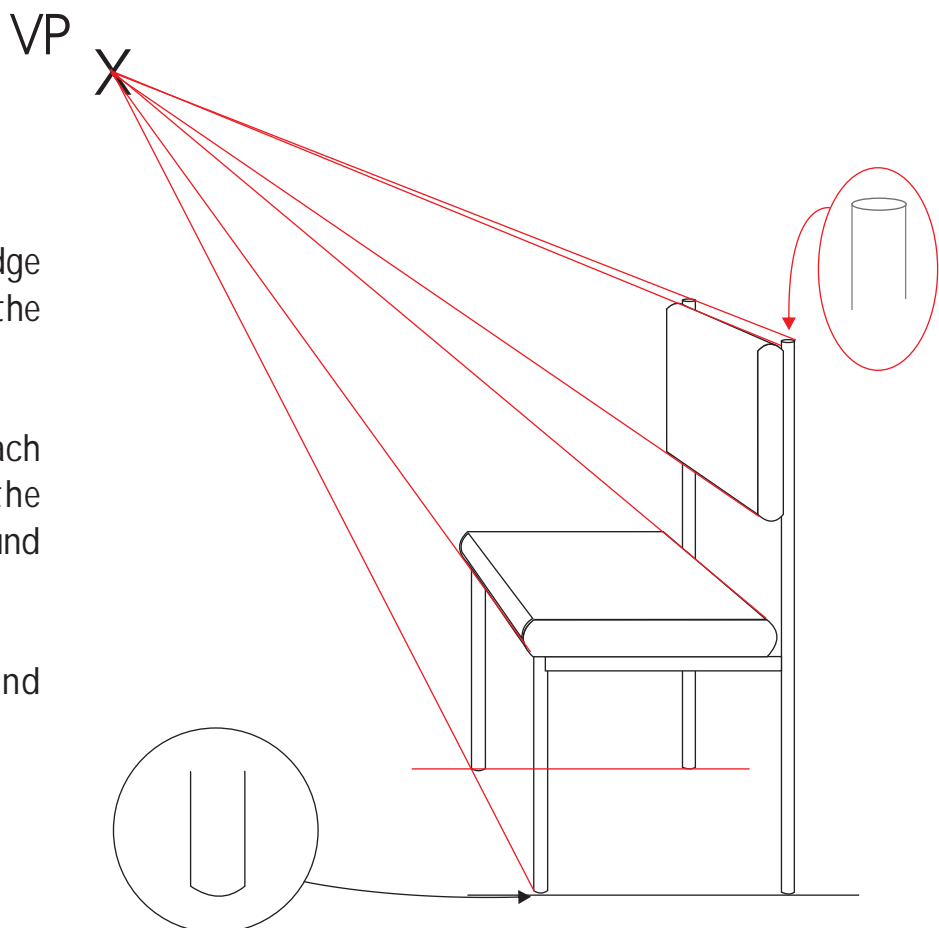

# SINGLE POINT PERSPECTIVE

---

V.Ryan © 2008 World Association of Technology Teachers

X

**1A.** Draw the chair seen below, in single point perspective.

**1B.** Add cushions.

**1C.** Add appropriate shade and colour.

